

SGR 062, SGR 042, SGR 022



30 × 25.3 × 12.5 mm

Small printed circuit board relay for dependable isolation of low-voltage control circuits from power current circuits. By virtue of its high switching capacity and small dimensions the ideal module for overcoming your switching problems.

Features and advantages

- simple, rugged design
- high contact switching capacity
- long life
- SEV-, VDE-, CSA-, DEMKO-, UL-, FI- and PTB-tested (PTB No. Ex-82/2082 U)
- leakage paths and air gaps > 14 mm between coil and contact circuits (VDE 0631/0730 and CENELEC EN 50020)
- low power input
- standardized grid size: 2.5 mm (according to DIN 40801)
- wave-solder-proof
- washproof with O-ring ZGR 008
- sealed, encapsulated (according to DIN 40046, sheet 15, Qc2) ZGR 009
- magnetic latching relay see separate data sheet 21.11.84
- bifurcated contacts
- plug-in socket ZGR 007 see data sheet 21.11.79

Application

Small apparatus, domestic appliances, metrology and control engineering

Execution

Flame-resistant plastic housing (UL 94-V1)
1 change-over contact 1 NO or 1 NC-optional
Suitable for machine soldering (tight bottom surface)

Technical data

Electrical data



350 Milford Point Rd. Milford, CT 06460 P.203-878-0400 F.203-878-0458

www.jaxxeninc.com

info@jaxxeninc.com

Operating voltages

6, 12, 24, 48, 60, 110 VDC
(for coil voltage range see diagrams)

Test voltage (coil – contacts)

5000 V_{rms}, 50 Hz

Switching capacity

220 VAC / 16 A, AC-1, 380 VAC / 6 A, AC-11

Insulation resistance

10¹¹ (in dry air)

Electrical life at 220 Vac, 16 A

about 200 000 operations, AC-1 (500 ops./h)

Capacitance

Contact-coil

about 1.8 pF

No-contact – NC-contact

about 1.6 pF

Coil table:

Nominal voltage

VDC

Coil resistance

±10% at +20°C

6

70

12

270

24

1100

48

4400 (±13%)

60

6850 (±15%)

110

20000 (±15%)

Mechanical data

Mechanical life

> 50 × 10⁶

Mechanical switching frequency

20 Hz (max. 40 Hz)

Response time

typically 10 ms

Release time

typically 3 ms

Bounce time: make contact

typically 0.5 ms

break contact

typically 5 ms

Contact design:

Contact material and diameter

AgCdO, 2 × 3 mm

Contact clearance

≥ 0.3 mm

Contact overtravel

about 0.3 mm

Other data

Ambient temperature
 Fire protection conditions to UL-94
 Operating position
 Weight

max. + 60°C
 V1
 any
 approx. 20 grams

Energizing voltage range

Duty cycle = 100% for all curves. Applies to all coils except 110 VDC version.

$$\frac{U_B}{U_N}$$

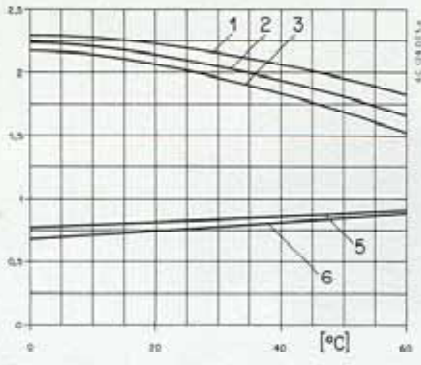

$$\frac{U_B}{U_N}$$

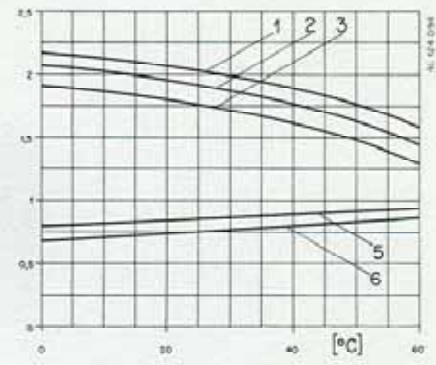

Individual relay on PCB,
 no heat accumulation due
 to surrounding components with self-heating.

2 or more relays side by side, at least
 7.5 mm apart, all relays operated
 simultaneously.

- 1: max. energizing voltage without contact loading
- 2: max. energizing voltage with contact loading 8 A
- 3: max. energizing voltage with contact loading 16 A
- *5: min. energizing voltage with prior operation at U_N
- *6: min. energizing voltage without prior operation

*Guaranteed values: typical values are lower.



350 Milford Point Rd. Milford, CT 06460 P.203-878-0400 F.203-878-0458
 www.jaxxeninc.com info@jaxxeninc.com

Dimensions

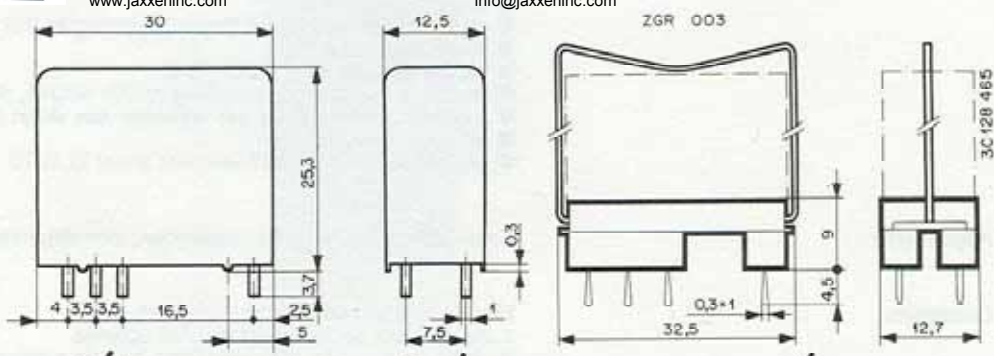

Wiring diagram

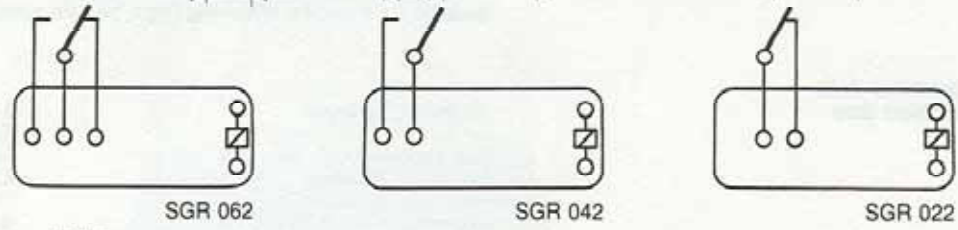

Drilling plan (soldering side)

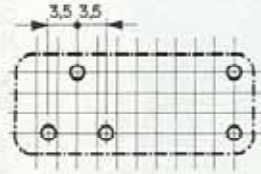

Grid 2.5 mm
 Holes 1.3 mm dia.

**With continuous current >10 A we
 recommend PCB holes through-connected!**

Ordering particulars

SGR 062 24 VDC (1 C-O)
 SGR 042 48 VDC (1 NO)
 SGR 022 12 VDC (1 NC), upon request

Special versions

Washable with O-ring
 Washproof, encapsulated
 Magnetically latched relay

SGR ... 12 VDC, ZGR 008
 SGR ... 24 VDC, ZGR 009
 SGR ... R12 VDC