



Series OU

Ultramini – clever – reliability in confined quarters

 4 m
Through-beam sensors OUS/OUE

 up to 2,1 m
Retro-reflective sensors OUR

 up to 2,1 m
Retro-reflective sensors
with polarizing filters OUP and OUC

 up to 10 cm
Diffuse-reflective sensors OUT



High functionality

Diverse operating principles

ELESTA's OU sensors are available as through-beam sensors, retro-reflective sensors with and without polarizing filters, retro-reflective sensors for transparent objects, as well as diffuse-reflective sensors.

Light reserve warning indicator

All of the sensors in the OU series contain a *light-reserve warning indicator* (blinking function indicator) for controlling dirt build-up on the lenses and as an *alignment aid*.

High switching frequency

All OU sensors have a 1000 Hz switching frequency, allowing for the reliable detection of even fast moving objects.

Low power consumption

The OU sensors distinguish themselves with an extremely small power consumption of less than 15 mA.

Test input

The OU through-beam sensors are available standard with *test input*, for confirming that the sensor is operating properly.

Simple installation and operation

Adjustable range

The optical range of the diffuse-reflective OU sensors can be adjusted to meet the specific application.

Various connection versions

All OU sensors are available standard with a 4 wire 2 m cable or a 4 pin M8 connector (snap-on or threaded).

Clever mounting concept

In contrast to the side mounting of traditional sensors, the OU mini-sensor from Elesta is designed for front or back mounting in the direction of the optical axis with only 10 mm depth. Thanks to recessed screws or nuts, a clean flush mounting is possible with no protruding parts. With two M3 screws and metal reinforced mounting holes, this mini-sensor can be fastened everywhere, simply and reliably.



Reliable for the highest demands

Robust construction with IP 67 sealing

The OU photoelectric sensors are built with a robust polycarbonate housing, and are protected against water and dust. The sensors meet the *sealing* requirements of IP 67.

EMC-tested

The OU sensors are tested according to IEC 801, EN50081-1 and EN50082-2. This assures trouble free use even in high electromagnetically contaminated environments.

High ambient light rejection

Thanks to pulse modulation and a very sensitive ambient light suppression with active disturbing light recognition and rejection, the OU sensors are extremely insensitive to foreign light sources e.g. HF-lamps, etc.

«Crosstalk» suppression

Through the active «crosstalk» suppression, the OU sensors function reliably even when oppositely mounted.

Reverse polarity protection

All of the OU sensor's electrical connections are protected against reverse wiring.

Short-circuit protection

The OU sensor's transistor outputs are electronically protected against short circuit.

Power-up output suppression

During power-up the outputs of the OU sensors are blocked for typically 90 msec.

Designation code

OU X XXX XXX XX

Principle	Supply	Outputs	Connection	Electr. option	Light	Range
C: Retro-reflective for transparent objects	1: 10-30 VDC	KA: No output NA: NPN <i>light- and dark-on</i>	1: Cable 2 m 5: Connector M8	00: Range adjustable 01: Range adjustable, <i>test input</i> 40: Range not adjustable 41: Range not adjustable, <i>test input</i>	I: infrared R: red	OUS/OUE: 1: 4 m OUR/OUP/OUC: 1: 1 m 2: 0,8 m OUT: 1: 5 cm 2: 10 cm
E: Through-beam receiver		PA: PNP <i>light- and dark-on</i>				
P: Retro-reflective with polarizing filters						
R: Retro-reflective						
S: Through-beam emitter						
T: Diffuse-reflective						
Z: Accessory						

Accessories

Retroreflectors: see page 130

Connector cables: see page 128

Diffuse-reflective sensors, range 5/10 cm, ultramini



- Front or back mounting in the direction of the optical axis
- Range adjustable
- Light reserve warning indicator
- Insensitive to foreign light sources, e.g. HF-lamps, etc.
- «Cross-talk» suppression for elimination of mutual disturbances
- Dual transistor outputs, NPN or PNP
- Short-circuit protection, reverse polarity protection, and power-up output suppression
- Connections: Cable, 2 meter
Connector, M8
- EMC tested according to IEC 801 and EN50081-1/EN 50082-2



Product designation ¹⁾

Output

Connection

Range adjustment

Optical data ²⁾

Max. range

Emitter

Electrical data ²⁾

Supply voltage U_s

Allowable ripple

Current consumption (without load)

Max. load current I_L

Residual voltage

Max. switching frequency

Environmental data

Sealing

Temperature T_A
(operating and storage)

Weight

OUT 1NA 100 R1	OUT 1NA 500 R1	OUT 1PA 100 R1	OUT 1PA 500 R1	OUT 1NA 100 R2	OUT 1NA 500 R2	OUT 1PA 100 R2	OUT 1PA 500 R2
NPN (light-/dark-on)		PNP (light-/dark-on)		NPN (light-/dark-on)		PNP (light-/dark-on)	
Cable 2 m	Connector M8	Cable 2 m	Connector M8	Cable 2 m	Connector M8	Cable 2 m	Connector M8
Yes							
5 cm (Kodak card white, 10 x 10 cm)				10 cm (Kodak card white, 10 x 10 cm)			
Red-LED, 650 nm, pulsed							
10...30 VDC							
+/- 10% of U_s							
< 15 mA							
100 mA							
< 1,6 V							
1000 Hz							
IP 67							
-25...+65 °C							
ca. 45 g	ca. 4 g	ca. 45 g	ca. 4 g	ca. 45 g	ca. 4 g	ca. 45 g	ca. 4 g

1) For product designation of sensors with options see designation code on page 13.

2) When not otherwise noted, all technical data at $T_A = 25\text{ °C}$ and $U_s = 24\text{ V}$.

10...30 VDC

NPN / PNP
light-on and
dark-on output

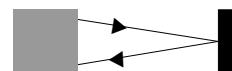

5/10 cm

OUT

Dimensions (30 mm x 10 mm x 14 mm)

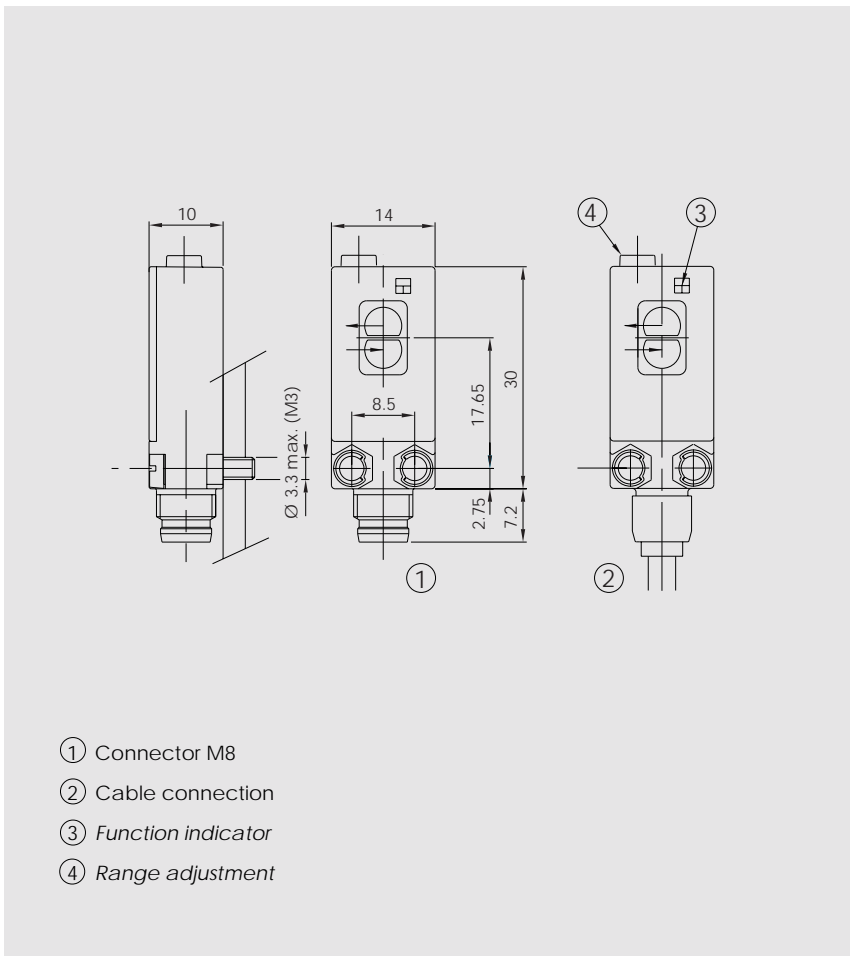

Optical diagrams

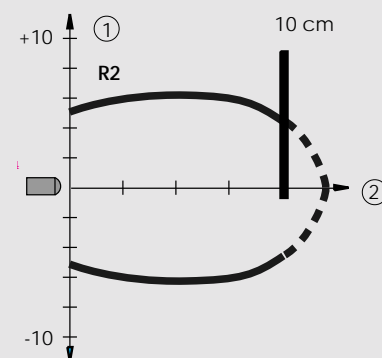
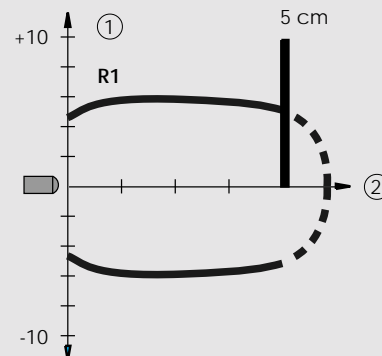

Typical beam diameter
(with Kodak card white, 10 x 10 cm)

- ① Diameter in (cm)
- ② Range in (cm)

Wiring diagram

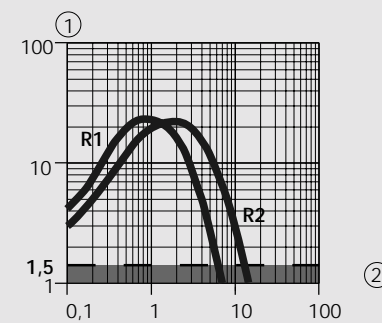
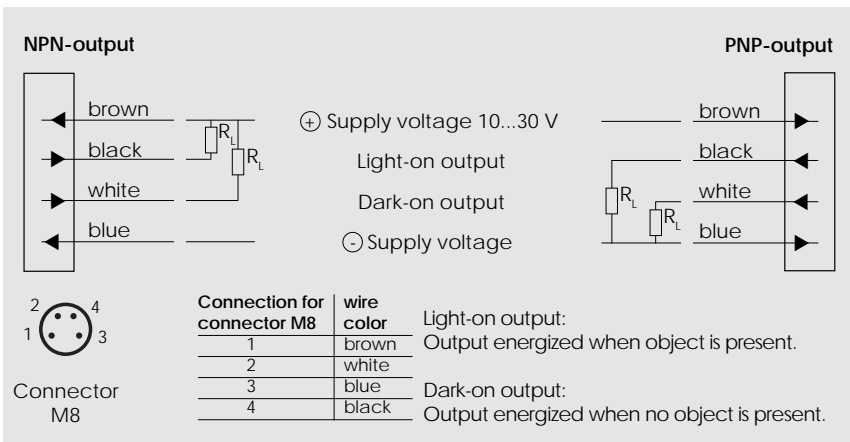

Typical excess gain curve
(with Kodak card white, 10 x 10 cm)

- ① Gain factor
- ② Range in (cm)