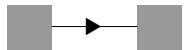
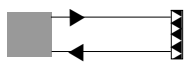
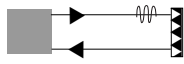

Series OP

Balanced – subtle – compact sensors for economical solutions

 12 m
Through-beam sensors OPS/OPE

 up to 8 m
Retro-reflective sensors OPR

 up to 7,5 m
Retro-reflective sensors with polarizing filters OPP

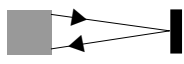
 up to 65 cm
Diffuse-reflective sensors OPT



High functionality

Diverse optical principles

ELESTA's OP sensors are available as through-beam sensors, retro-reflective sensors with and without polarizing filters, as well as diffuse-reflective sensors. Additionally, diffuse-reflective sensors with *background suppression* are available. Within the series OP also sensors for glass or plastic fiber optics exist (see page 118).

Light reserve warning indicator

All of the sensors in the OP series contain a *light-reserve warning indicator* (blinking function indicator) for controlling dirt build-up on the lenses and as an *alignment aid*.

High switching frequency

All OP sensors have a 1000 Hz switching frequency, allowing for the reliable detection of even fast moving objects.

Low power consumption

The OP sensors distinguish themselves with an extremely small power consumption of less than 15 mA.

Test input as option

As an option, the OP sensors are available with *test input*, for confirming that the sensor is operating properly. A sensor with *test input* has only one output, either *light-on* or *dark-on*.

Simple installation and operation

Adjustable range

The optical *range* of each OP sensor can be adjusted to meet the specific application.

Various connection versions

All OP sensors are available standard with a 2m cable or an M12 connector. As an option, the OP sensors are available with an M8 connector, or a Torson connector.

User friendly, even in tight spaces

The range adjustment potentiometer is conveniently located at the back of the sensor. This is especially advantageous in tight spaces. A luminous *function indicator* is easily seen from the back and side of the sensor even in bright daylight conditions.

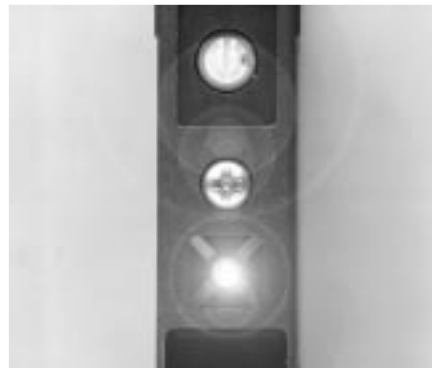

Reliable for the highest demands

Robust construction with IP 65 sealing

The OP photoelectric sensors are built with a glass-sphere reinforced polyamide housing, and are protected against water and dust. The sensors meet the *sealing* requirements of IP 65.

EMC-tested

The OP sensors are tested according to IEC 801, EN50081-1 and EN50082-2. This assures trouble free use even in high electromagnetically contaminated environments.

High ambient light rejection

Thanks to pulse modulation and a multilevel disturbance rejection, the OP sensors are extremely insensitive to foreign light sources.

Reverse polarity protection

All of the OP sensor's electrical connections are protected against reverse wiring.

Short-circuit protection

The OP sensor's transistor outputs are electronically protected against short circuit.

Power-up output suppression

During power-up the outputs of the OP sensors are blocked for typically 30 msec.

Designation code

OP x xxx xxx xx

Principle	Supply	Outputs	Connection	Electr. option	Light	Range
E: Through-beam receiver	1: 10-30 VDC	KA: No output NA: NPN <i>light- and dark-on</i> ND: NPN <i>dark-on</i> NH: NPN <i>light-on</i> PA: PNP <i>light- and dark-on</i> PD: PNP <i>dark-on</i> PH: PNP <i>light-on</i>	0: Cable special length 1: Cable 2 m 4: Connector M12 5: Connector M8 6: Connector Torson	00: Range adjustable 01: Range adjustable, <i>test input</i> 40: Range not adjustable 41: Range not adjustable, <i>test input</i>	I: Infrared R: Red	OPS/OPE: 1: 12 m OPP/OPR: 1: 3,5 m 2: 4 m OPT: 1: 40 cm 2: 5 cm 3: 10 cm 4: 20 cm 5: 65 cm
P: Retro-reflective with polarizing filters						
R: Retro-reflective						
S: Through-beam emitter						
T: Diffuse-reflective						
Z: Accessory						

Accessories

Retroreflectors: see page 130

Connector cables: see page 128

Mounting:

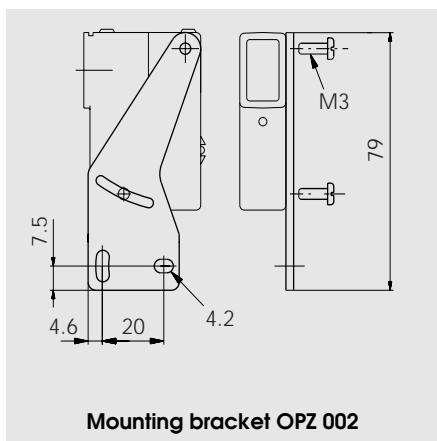
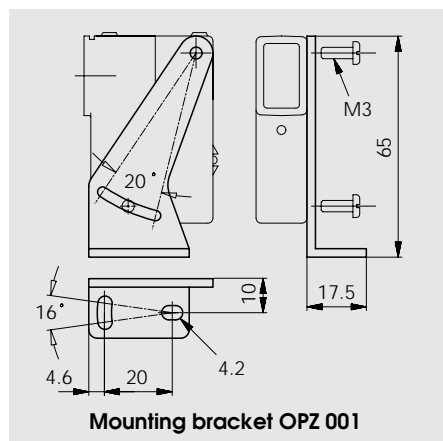

Through-beam sensors, in a small plastic housing



- Light reserve warning indicator
- Dual transistor outputs, NPN or PNP
- 1000 Hz switching frequency
- Short-circuit protection, reverse polarity protection and power-up output suppression
- Test input
- Connections: Cable, 2 meter
Connector, M12
Connector, M8 (option)
Connector, Torson (option)
- EMC tested according to IEC 801 and EN50081-1/EN 50082-2



Product designation ¹⁾

Output
Connection
Range adjustment

Optical data ²⁾

Max. range
Emitter

Electrical data ²⁾

Supply voltage U_s
Allowable ripple
Current consumption (without load)
Max. load current I_L
Residual voltage
Max. switching frequency
Test input: emitter on emitter off
Test input inverse: emitter on emitter off

Environmental data

Sealing
Temperature T_A (operating and storage)
Weight

Emitter		Receiver			
OPS 1KA 141 II	OPS 1KA 441 II	OPE 1NA 100 II	OPE 1NA 400 II	OPE 1PA 100 II	OPE 1PA 400 II
		NPN (light- and dark-on)		PNP (light- and dark-on)	
Cable 2 m	Connector M12	Cable 2 m	Connector M12	Cable 2 m	Connector M12
No		Yes			
12 m					
Infrared-LED, 880 nm, pulsed					
10...30 VDC					
+/- 10% of U_s					
< 25 mA		< 15 mA			
		200 mA			
		< 1,6 V			
		1000 Hz			
> 8 V or open < 1,5 V					
open or < 1,5 V > 8 V					
IP 65					
-25...+65 °C					
ca. 100 g	ca. 35 g	ca. 100 g	ca. 35 g	ca. 100 g	ca. 35 g

1) For product designation of sensors with options see designation code on page 81.
2) When not otherwise noted, all technical data at $T_A = 25\text{ °C}$ and $U_s = 24\text{ V}$.

10...30 VDC

NPN / PNP
light-on and
dark-on output



12 m

OPS/OPE

Dimensions (55 mm x 38 mm x 15 mm)

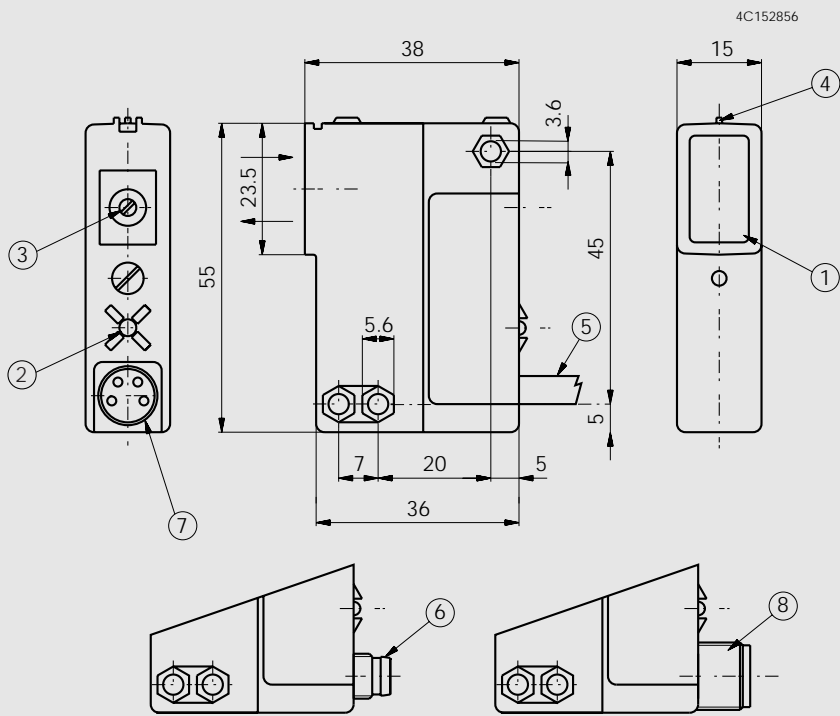

- ① Optics
- ② Emitter: operation indicator
Receiver: function indicator
- ③ Range adjustment
- ④ Alignment aid
- ⑤ Cable connection
- ⑥ Connector M8
- ⑦ Connector Torson
- ⑧ Connector M12

Optical diagrams

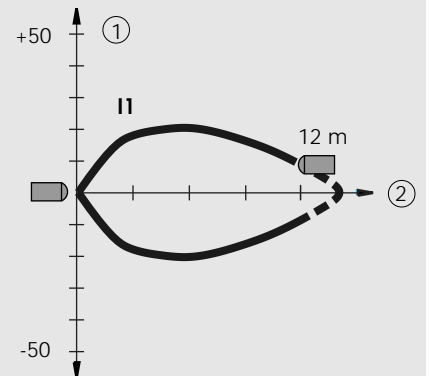

Typical beam diameter

- ① Diameter in (cm)
- ② Range in (m)

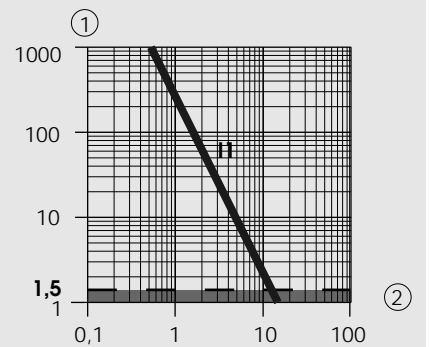

Typical excess gain curve

- ① Gain factor
- ② Range in (m)

Wiring diagram

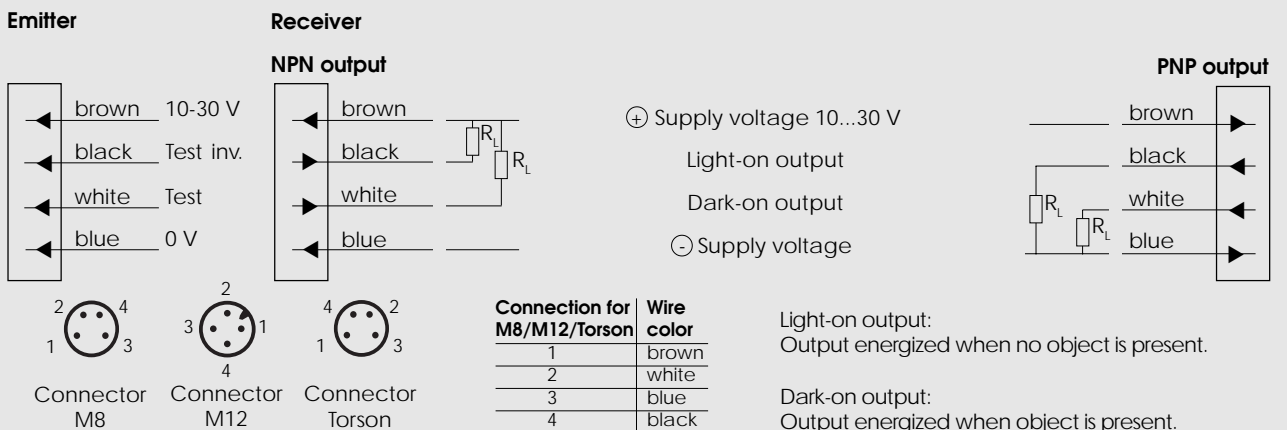

Retro-reflective sensors, in a small plastic housing



- Light reserve warning indicator
- Dual transistor outputs, NPN or PNP
- 1000 Hz switching frequency
- Short-circuit protection, reverse polarity protection and power-up output suppression
- Test input (option)
- Connections: Cable, 2 meter
Connector, M12
Connector, M8 (option)
Connector, Torson (option)
- EMC tested according to IEC 801 and EN50081-1/EN 50082-2



Product designation ¹⁾

Output
Connection
Range adjustment

Optical data ²⁾

Range
Emitter

Electrical data ²⁾

Supply voltage U_s
Allowable ripple
Current consumption (without load)
Max. load current I_L
Residual voltage
Max. switching frequency

Environmental data

Sealing
Temperature T_A (operating and storage)
Weight

Option ¹⁾

Test input: emitter on
emitter off

OPR 1NA 100 I2	OPR 1NA 400 I2	OPR 1PA 100 I2	OPR 1PA 400 I2
NPN (light- and dark-on)		PNP (light- and dark-on)	
Cable 2 m	Connector M12	Cable 2 m	Connector M12
Yes			
0,05...4 m (retroreflector OZR 001)			
Infrared-LED, 950 nm, pulsed			
10...30 VDC			
+/- 10% of U_s			
< 15 mA			
200 mA			
< 1,6 V			
1000 Hz			
IP 65			
-25...+65 °C			
ca. 100 g	ca. 35 g	ca. 100 g	ca. 35 g

+ U_s or open	
< 1,5 V	< U_s - 8 V

1) For product designation of sensors with options see designation code on page 81.

2) When not otherwise noted, all technical data at $T_A = 25\text{ °C}$ and $U_s = 24\text{ V}$.

Retro-reflector ●	Range	Retro-reflector ■	Range	Retro-reflective tape	Range
OZR 001	0.05 – 4.0 m	OZR 101	0.05 – 6.0 m	OZR 201*	0.15 – 1.4 m
OZR 002	0.03 – 3.5 m	OZR 102	0.05 – 2.2 m	OZR 202	0.15 – 3.0 m
OZR 003	0.03 – 1.6 m	OZR 103	0.03 – 4.8 m	OZR 203	0.15 – 2.3 m
		OZR 104	0.03 – 8.0 m	OZR 204*	0.15 – 2.0 m
				OZR 205*	0.15 – 2.9 m

* 30 cm long

10...30 VDC

NPN / PNP
light-on and
dark-on output

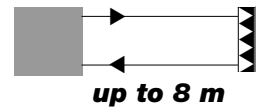

OPR

Dimensions (55 mm x 38 mm x 15 mm)

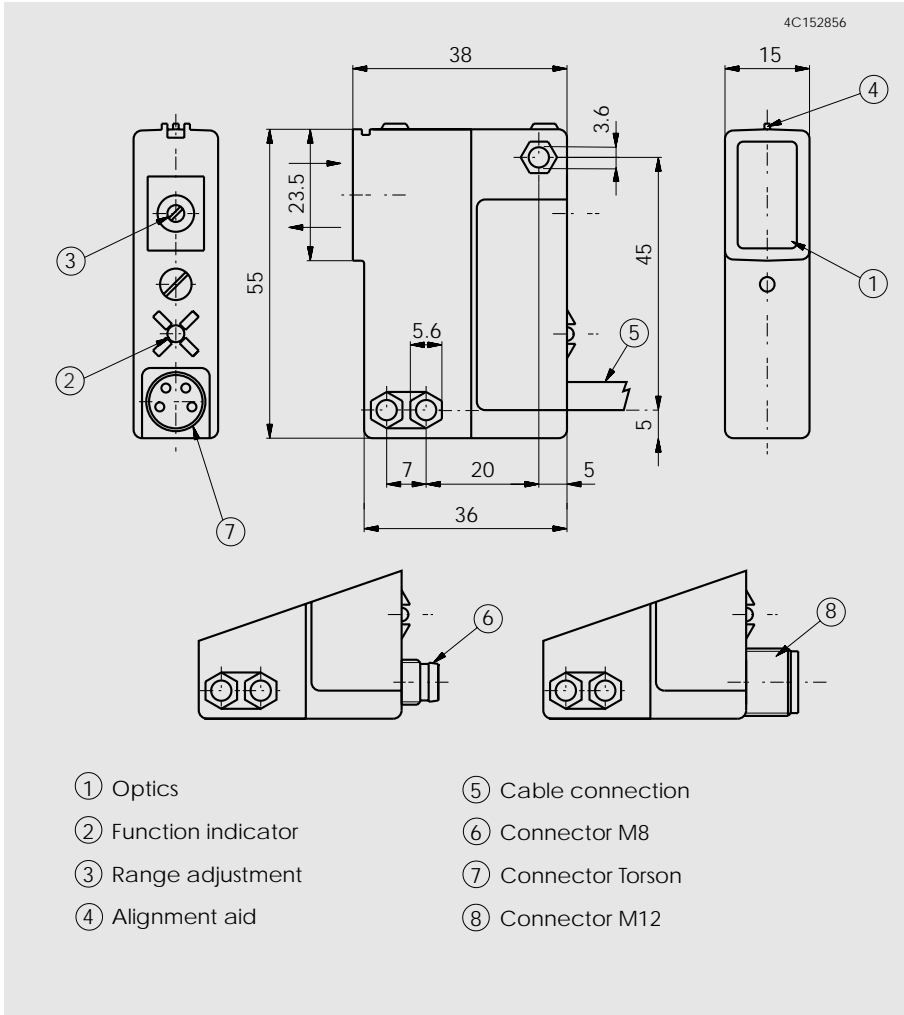

Optical diagrams

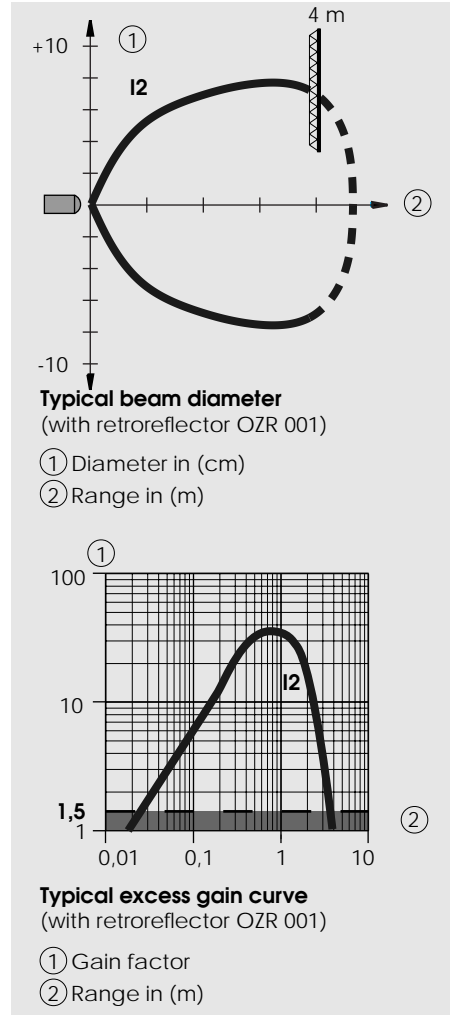

Wiring diagram

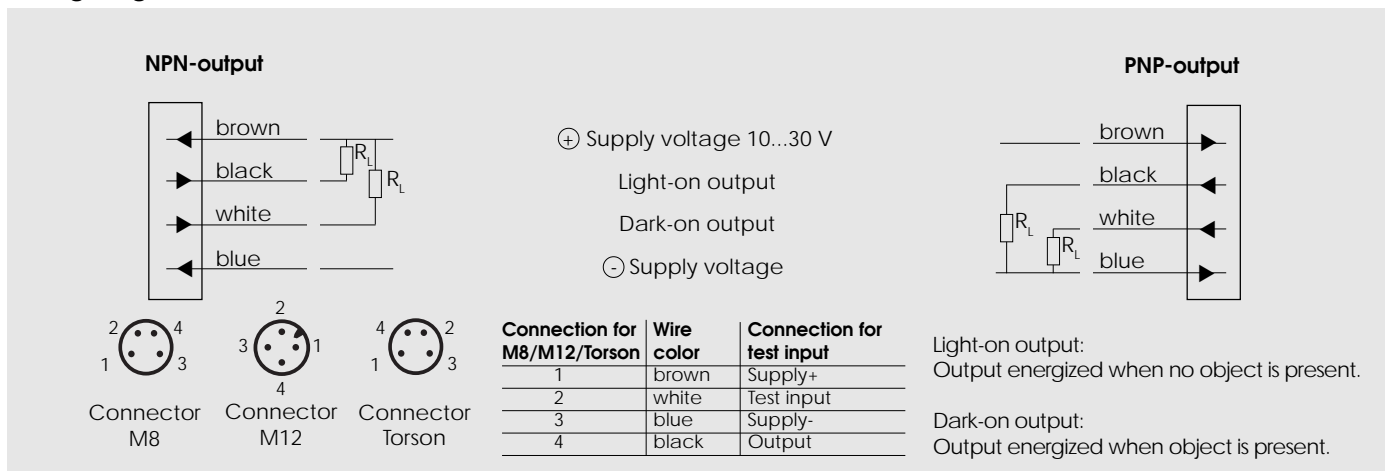

Retro-reflective sensors with polarizing filters, in a small plastic housing



- Glass protected optics
- Light reserve warning indicator
- Dual transistor outputs, NPN or PNP
- 1000 Hz switching frequency
- Short-circuit protection, reverse polarity protection and power-up output suppression
- Test input (option)
- Connections: Cable, 2 meter
Connector, M12
Connector, M8 (option)
Connector, Torson (option)
- EMC tested according to IEC 801 and EN50081-1/EN 50082-2



Product designation ¹⁾

Output
Connection
Range adjustment

Optical data ²⁾

Range
Emitter

Electrical data ²⁾

Supply voltage U_s
Allowable ripple
Current consumption (without load)
Max. load current I_L
Residual voltage
Max. switching frequency

Environmental data

Sealing
Temperature T_A (operating and storage)
Weight

Option ¹⁾

Test input: emitter on
emitter off

OPP 1NA 100 R1	OPP 1NA 400 R1	OPP 1PA 100 R1	OPP 1PA 400 R1
NPN (light- and dark-on)		PNP (light- and dark-on)	
Cable 2 m	Connector M12	Cable 2 m	Connector M12
Yes			
0,1...3,5 m (retroreflector OZR 001)			
Visible-red LED, 660 nm, pulsed, with polarizing filter			
10...30 VDC			
+/- 10% of U_s			
< 15 mA			
200 mA			
< 1,6 V			
1000 Hz			
IP 65			
-25...+65°C			
ca. 100 g	ca. 35 g	ca. 100 g	ca. 35 g

+ U_s or open	
< 1,5 V	< U_s - 8 V

1) For product designation of sensors with options see designation code on page 81.

2) When not otherwise noted, all technical data at $T_A = 25^\circ\text{C}$ and $U_s = 24\text{ V}$.

Retro-reflector ●	Range	Retro-reflector ■	Range	Retro-reflective tape	Range
OZR 001	0.10 – 3.5 m	OZR 101	0.10 – 5.8 m	OZR 201*	0 m
OZR 002	0.08 – 3.3 m	OZR 102	0.10 – 1.9 m	OZR 202	0 m
OZR 003	0.15 – 1.3 m	OZR 103	0.08 – 4.6 m	OZR 203	0.25 – 1.8 m
		OZR 104	0.08 – 7.5 m	OZR 204*	0.25 – 1.3 m
				OZR 205*	0.25 – 1.8 m

* 30 cm long

10...30 VDC

NPN / PNP
light-on and
dark-on output

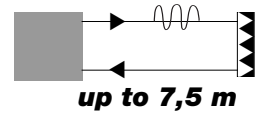

OPP

Dimensions (55 mm x 38 mm x 15 mm)

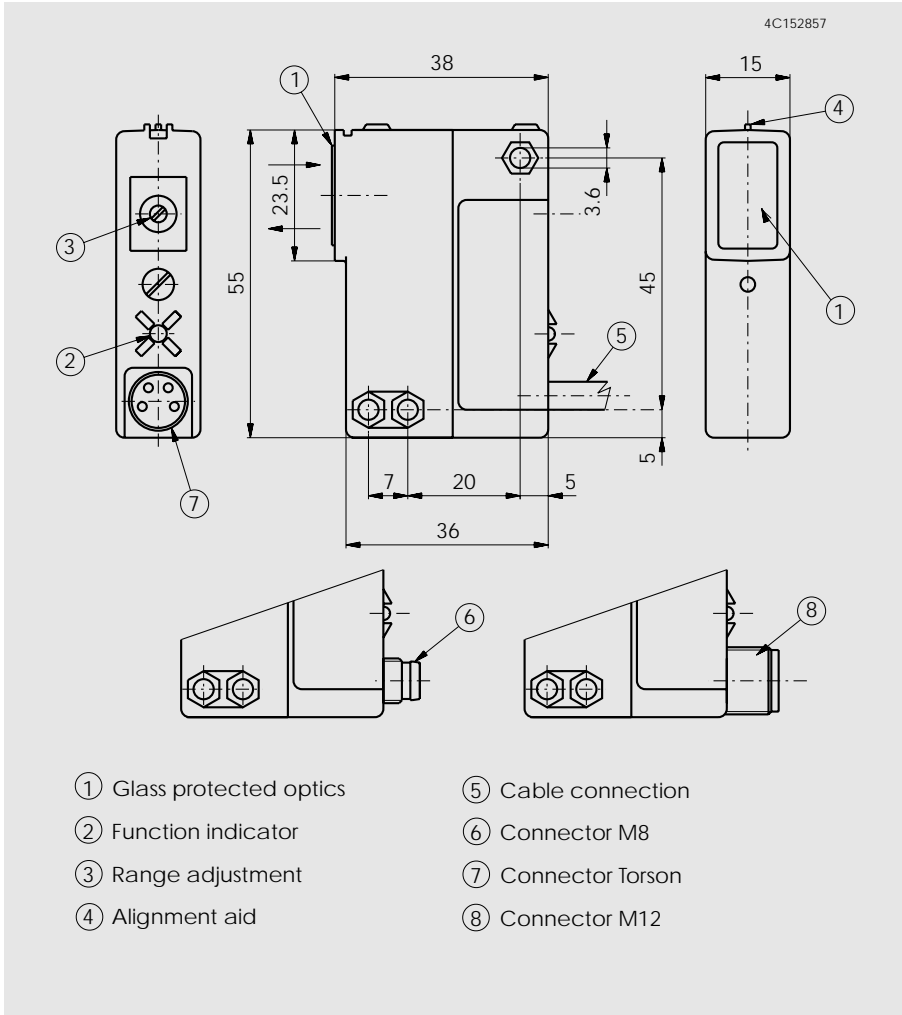

Optical diagrams

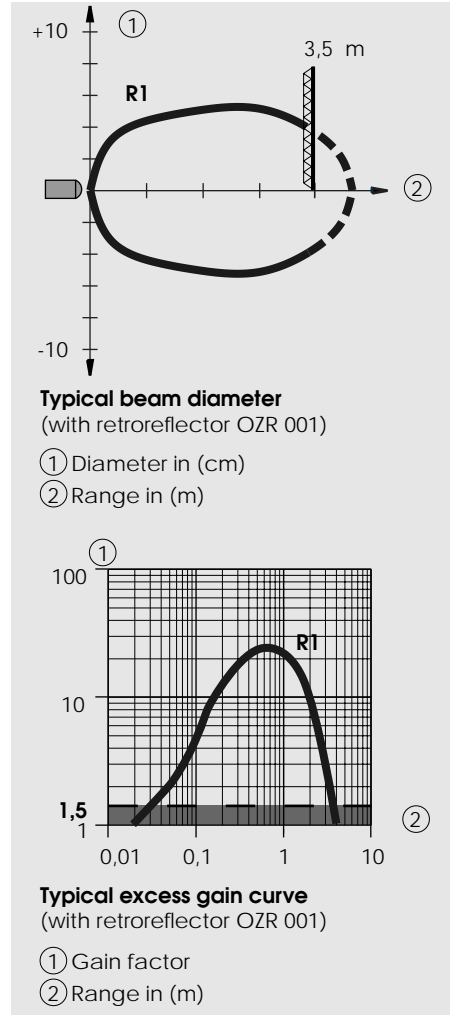

Wiring diagram

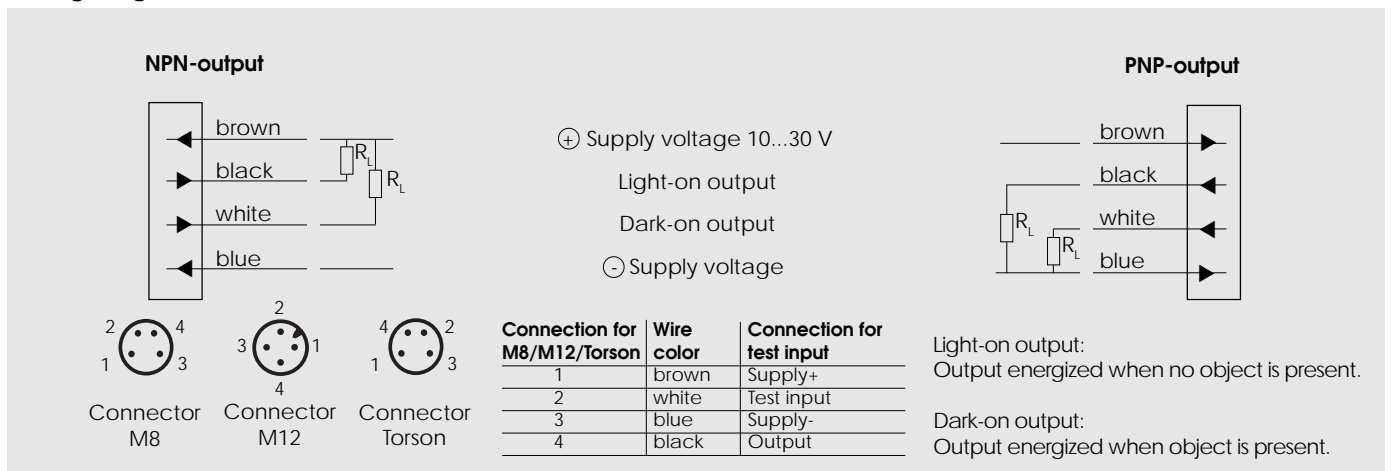

Diffuse-reflective sensors, range 5/10 cm, with background suppression, in a small plastic housing



- Background suppression
- Light reserve warning indicator
- Dual transistor outputs, NPN or PNP
- 1000 Hz switching frequency
- Short-circuit protection, reverse polarity protection and power-up output suppression
- Connections: Cable, 2 meter
Connector, M12
Connector, M8 (option)
Connector, Torson (option)
- EMC tested according to IEC 801 and EN 50081-1/EN 50082-2



Product designation ¹⁾

Output

Connection

Range adjustment

Optical data ²⁾

Max. range

Emitter

Electrical data ²⁾

Supply voltage U_s

Allowable ripple

Current consumption (without load)

Max. load current I_L

Residual voltage

Max. switching frequency

Environmental data

Sealing

Temperature T_A
(operating and storage)

Weight

OPT 1NA 100 I2	OPT 1NA 400 I2	OPT 1PA 100 I2	OPT 1PA 400 I2	OPT 1NA 100 I3	OPT 1NA 400 I3	OPT 1PA 100 I3	OPT 1PA 400 I3
NPN (light-/dark-on)		PNP (light-/dark-on)		NPN (light-/dark-on)		PNP (light-/dark-on)	
Cable 2 m	Connector M12	Cable 2 m	Connector M12	Cable 2 m	Connector M12	Cable 2 m	Connector M12
Yes							
5 cm (Kodak card white, 10 x 10 cm)				10 cm (Kodak card white, 10 x 10 cm)			
Infrared-LED, 880 nm, pulsed							
10...30 VDC							
+/- 10% of U_s							
< 15 mA							
200 mA							
< 1,6 V							
1000 Hz							
IP 65							
-25...+65 °C							
ca. 100 g	ca. 35 g	ca. 100 g	ca. 35 g	ca. 100 g	ca. 35 g	ca. 100 g	ca. 35 g

1) For product designation of sensors with options see designation code on page 81.

2) When not otherwise noted, all technical data at $T_A = 25\text{ °C}$ and $U_s = 24\text{ V}$.

10...30 VDC

NPN / PNP
light-on and
dark-on output

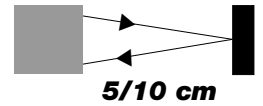

OPT

Dimensions (55 mm x 38 mm x 15 mm)

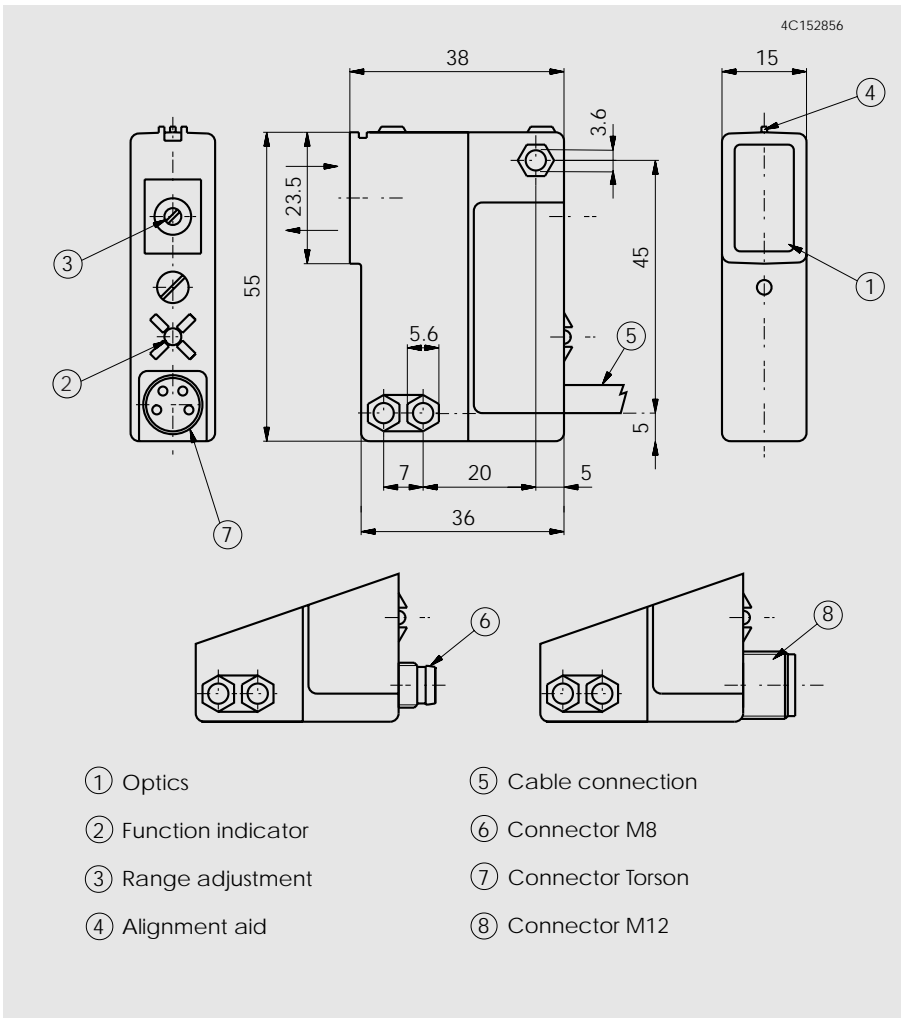

Optical diagrams

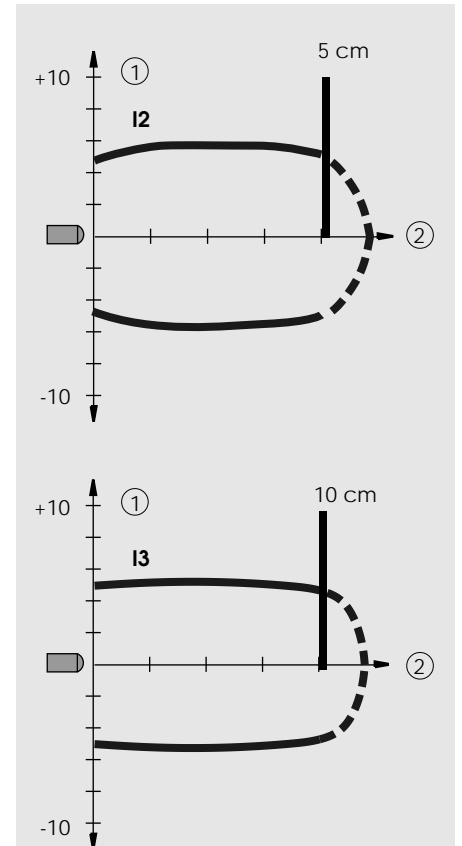

Typical beam diameter

(with Kodak card white, 10 x 10 cm)

① Diameter in (cm)

② Range in (cm)

Wiring diagram

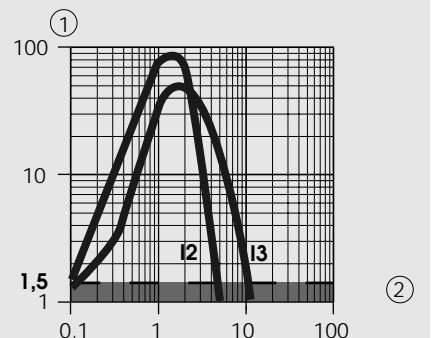
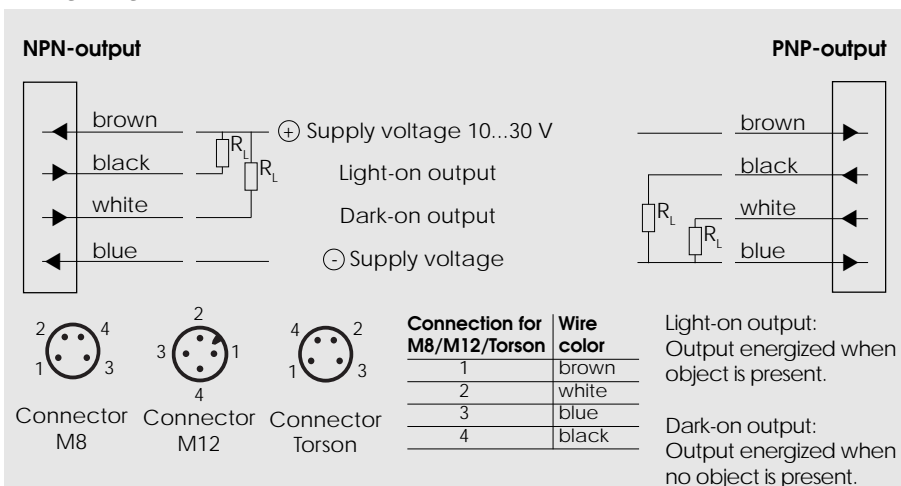

Typical excess gain curve

(with Kodak card white, 10 x 10 cm)

① Gain factor

② Range in (cm)

Diffuse-reflective sensors, range 20/40/65 cm, in a small plastic housing



- Light reserve warning indicator
- Dual transistor outputs, NPN or PNP
- 1000 Hz switching frequency
- Short-circuit protection, reverse polarity protection and power-up output suppression
- Connections: Cable, 2 meter
Connector, M12
Connector, M8 (option)
Connector, Torson (option)
- EMC tested according to IEC 801 and EN 50081-1/EN 50082-2



Product designation ¹⁾ 20 cm Sensor

Product designation ¹⁾ 40 cm Sensor

Product designation ¹⁾ 65 cm Sensor

Output

Connection

Range adjustment

Optical data ²⁾

Max. range

Emitter

Electrical data ²⁾

Supply voltage U_s

Allowable ripple

Current consumption (without load)

Max. load current I_L

Residual voltage

Max. switching frequency

Environmental data

Sealing

Temperature T_A
(operating and storage)

Weight

	OPT 1NA 100 I4	OPT 1NA 400 I4	OPT 1PA 100 I4	OPT 1PA 400 I4
	OPT 1NA 100 I1	OPT 1NA 400 I1	OPT 1PA 100 I1	OPT 1PA 400 I1
	OPT 1NA 100 I5	OPT 1NA 400 I5	OPT 1PA 100 I5	OPT 1PA 400 I5
Output	NPN (light- and dark-on)		PNP (light- and dark-on)	
Connection	Cable 2 m	Connector M12	Cable 2 m	Connector M12
Range adjustment	Yes			
Optical data ²⁾				
Max. range	I4: 20 cm / I1: 40 cm / I5: 65 cm (Kodak card withe, 10 x 10 cm)			
Emitter	Infrared-LED, 880 nm, pulsed			
Electrical data ²⁾				
Supply voltage U_s	10...30 VDC			
Allowable ripple	+/- 10% of U_{Sp}			
Current consumption (without load)	< 15 mA			
Max. load current I_L	200 mA			
Residual voltage	< 1,6 V			
Max. switching frequency	1000 Hz			
Environmental data				
Sealing	IP 65			
Temperature T_A (operating and storage)	-25...+65 °C			
Weight	ca. 100 g	ca. 35 g	ca. 100 g	ca. 35 g

1) For product designation of sensors with options see designation code on page 81.

2) When not otherwise noted, all technical data at $T_A = 25\text{ °C}$ and $U_s = 24\text{ V}$.

10...30 VDC

NPN / PNP
light-on and
dark-on output

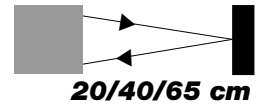

OPT

Dimensions (55 mm x 38 mm x 15 mm)

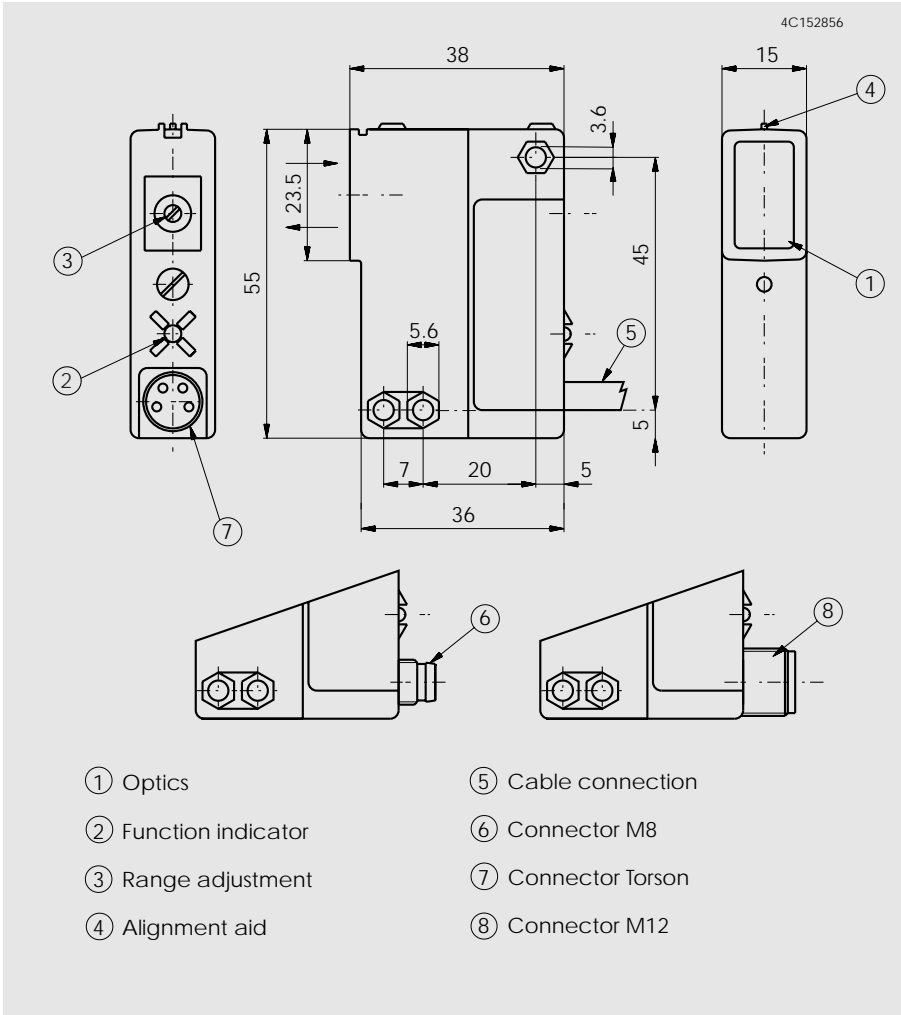

Optical diagrams

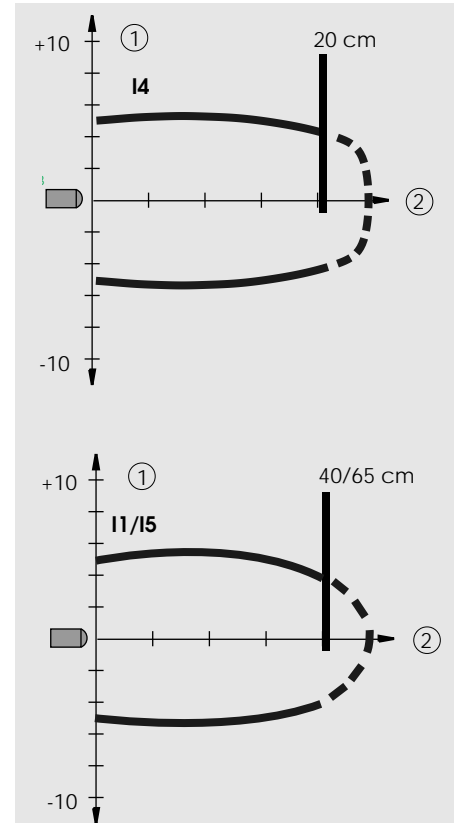

Typical beam diameter

(with Kodak card white, 10 x 10 cm)

① Diameter in (cm)
② Range in (cm)

Wiring diagram

