



Series OM

Versatile - nifty - slim sensors with an outstanding profile

 up to 9 m
Through-beam sensors OMS/OME

 up to 6,2 m
Retro-reflective sensors OMR

 up to 4,7 m
Retro-reflective sensors
with polarizing filters OMP

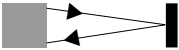
 up to 65 cm
Diffuse-reflective sensors OMT



High functionality

Diverse operating principles

ELESTA's OM sensors are available as through-beam sensors, retro-reflective sensors with and without polarizing filters, as well as diffuse-reflective sensors. The OM sensors can also be used with fiber optic cables.

Light reserve warning indicator

All of the sensors in the OM series contain a light-reserve warning indicator (blinking function indicator) for controlling dirt build-up on the lenses and as an alignment aid.

High ambient temperature

These photoelectric sensors can be used for ambient temperatures up to +90° C (at reduced supply voltage).

High switching frequency

All OM sensors have a 1000 Hz switching frequency, allowing for the reliable detection of even fast moving objects.

Low power consumption

The OM sensors distinguish themselves with an extremely small power consumption of less than 15 mA.

Test input as option

As an option, the OM sensors are available with test input, for confirming that the sensor is operating properly. A sensor with test input has only one output, either light-on or dark-on.

Simple installation and operation

Adjustable range

The optical range of each OM sensor can be adjusted to meet the specific application.

Angle optics

The right angle optics version of this series has a special user-friendly design. The diameter of the optic head is no greater than that of the sensor housing. Therefore, also the angle optics versions of the OM sensors are easy to install, even in bore mounting applications.

Various connection versions

All OM sensors are available standard with a 2m cable or an M12 connector. As an option, the OM sensors are available with a right angle 2m cable, or a Torson connector.

Combined surface and bore mounting

The ELESTA OM sensors distinguish themselves with a special housing concept. They can be bore mounted or flat mounted on a surface with two M4 screws.



Reliable for the highest demands

Robust construction with IP 67 sealing

The OM photoelectric sensors are built with a glass-sphere reinforced polyamide housing, and are protected against water and dust. The sensors meet the sealing requirements of IP 67.

EMC-tested

The OM sensors are tested according to IEC 801, EN50081-1 and EN50082-2. This assures trouble free use even in high electromagnetically contaminated environments.

High ambient light rejection

Thanks to pulse modulation and a multilevel disturbance rejection, the OM sensors are extremely insensitive to foreign light sources.

Reverse polarity protection

All of the OM sensor's electrical connections are protected against reverse wiring.

Short-circuit protection

The OM sensor's transistor outputs are electronically protected against short circuit.

Power-up output suppression

During power-up the outputs of the OM sensors are blocked for typically 30 msec.

Glass-protected optics

Partially standard, but also as an option, the OM sensors are available with a glass window to protect the optics against aggressive chemicals and mechanical damage (scratching).

Designation code

OM X XXX XXX XX

Principle	Supply	Outputs	Connection	Electr. option	Light	Range
E: Through-beam receiver	1: 10-30 VDC	KA: No output	0: Cable special length	00: Range adjustable	A: Right angle optic, red	OMS/OME: 1: 9 m 2: 8 m
P: Retro-reflective with polarizing filters		NA: NPN light- and dark-on	1: Cable 2 m	01: Range adjustable, test input	G: Straight optic, infrared	OMP/OMR: 1: 2 m 2: 2 m 3: 3 m
R: Retro-reflective		ND: NPN dark-on	2: Angled cable 2 m	40: Range not adjustable	S: Straight optic, red	OMT: 1: 10 cm 2: 20 cm 3: 40 cm 4: 65 cm
S: Through-beam emitter		NH: NPN light-on	4: Connector M12	41: Range not adjustable, test input	W: Right angle optic, infrared	
T: Diffuse-reflective		PA: PNP light- and dark-on	6: Connector Torson			
Z: Accessory		PD: PNP dark-on				
		PH: PNP light-on				

Accessories

Retroreflectors: see page 130

Connector cables: see page 128

Mounting:

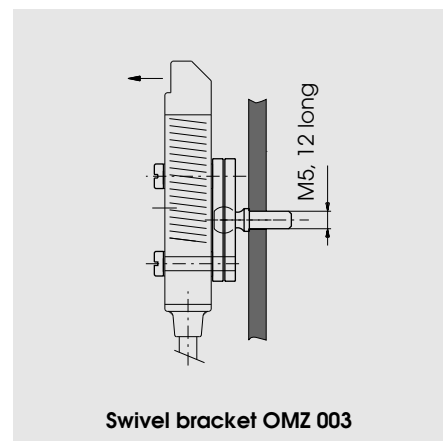
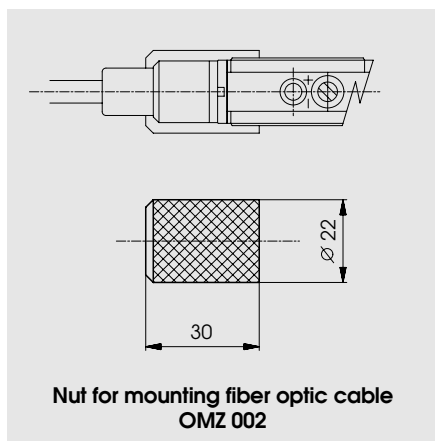
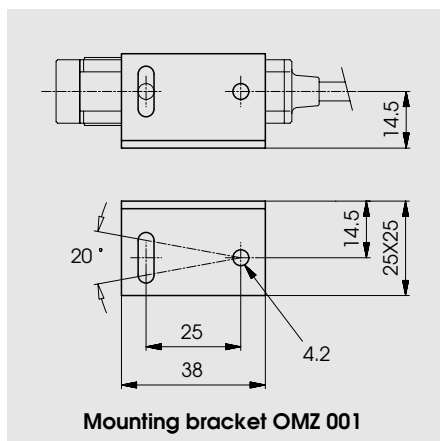

Diffuse-reflective sensors, range 10/20 cm, straight optics, M18 housing



- Combined surface and bore mounting
- Light reserve warning indicator
- Dual transistor outputs, NPN or PNP
- 1000 Hz switching frequency
- Short-circuit protection, reverse polarity protection, and power-up output suppression
- Connections: Straight cable, 2 meter
Connector, M12
Right angle cable, 2 meter (option)
Connector, Torson (option)
- EMC tested according to IEC 801 and EN50081-1/EN 50082-2



Product designation ¹⁾	OMT 1NA 100 G1	OMT 1NA 400 G1	OMT1PA 100 G1	OMT 1PA 400 G1	OMT 1NA 100 G2	OMT 1NA 400 G2	OMT1PA 100 G2	OMT 1PA 400 G2
Output	NPN (light-/dark-on)		PNP (light-/dark-on)		NPN (light-/dark-on)		PNP (light-/dark-on)	
Connection	Cable 2 m	Connector M12	Cable 2 m	Connector M12	Cable 2 m	Connector M12	Cable 2 m	Connector M12
Range adjustment	Yes							
Optical data ²⁾								
Max. range	10 cm (Kodak card white, 10 x 10 cm)				20 cm (Kodak card white, 10 x 10 cm)			
Emitter	Infrared-LED, 880 nm, pulsed							
Electrical data ²⁾								
Supply voltage U_s	10...30 VDC							
Allowable ripple	+/- 10% of U_{sp}							
Current consumption (without load)	< 15 mA							
Max. load current I_L	200 mA							
Residual voltage	< 1,6 V							
Max. switching frequency	1000 Hz							
Environmental data								
Sealing	IP 67							
Temperature T_A (operating and storage)	-20...+90 °C (☛ Tech. explanation)							
Weight	ca. 90 g	ca. 20 g	ca. 90 g	ca. 20 g	ca. 90 g	ca. 20 g	ca. 90 g	ca. 20 g

1) For product designation of sensors with options see designation code on page 47.

2) When not otherwise noted, all technical data at $T_A = 25\text{ °C}$ and $U_s = 24\text{ V}$.

Note:

This OMT sensor (range 20 cm) can also be used as a fiber optic sensor. The corresponding fiber optic cables can be found in the fiber optic chapter (page 124).

Technical explanation

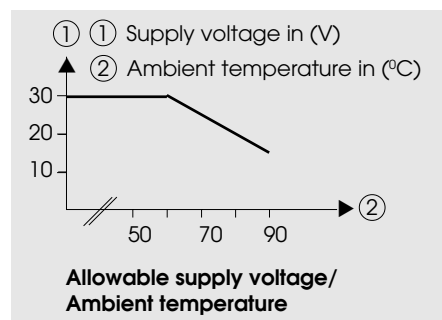

Allowable supply voltage as a function of ambient temperature

The specified operating temperature is only usable if the supply voltage is reduced at higher temperatures (☛ Diagram "Allowable supply voltage/Ambient temperature").

10...30 VDC

NPN / PNP
light-on and
dark-on output

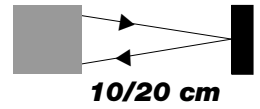

OMT straight optics

Dimensions (59 mm, M18 x 1)

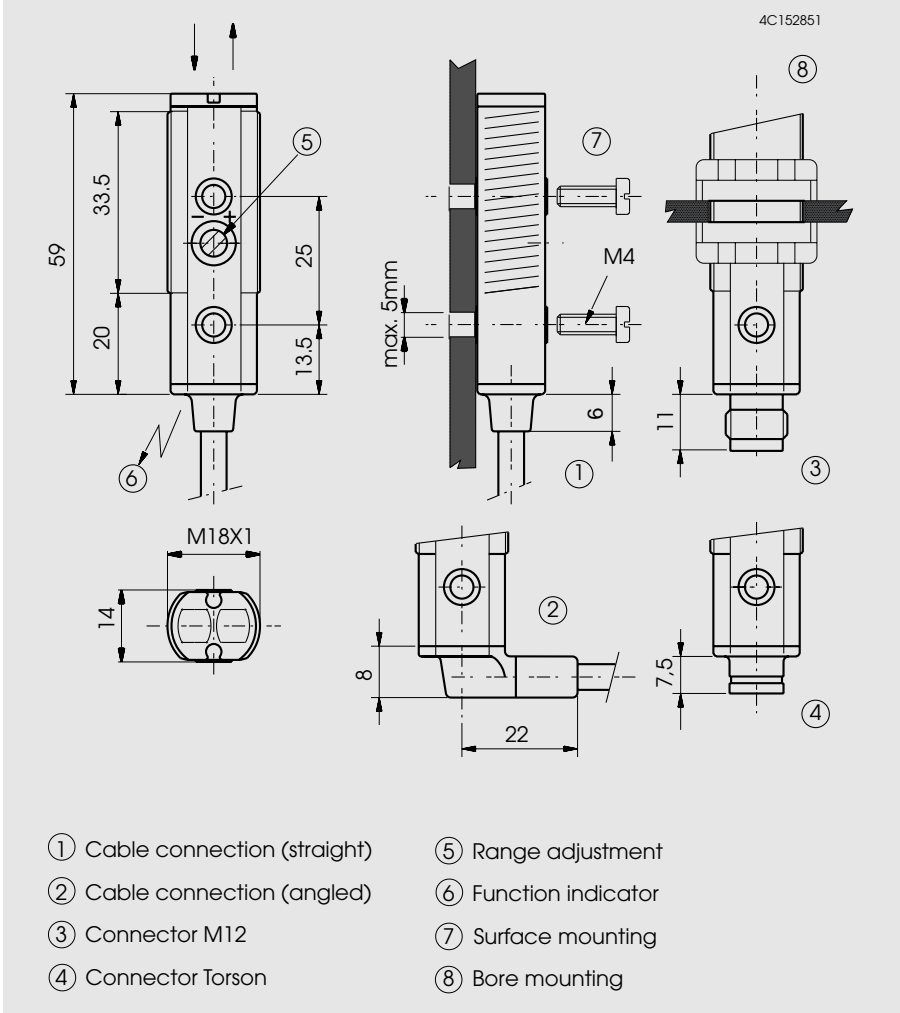

Optical diagrams

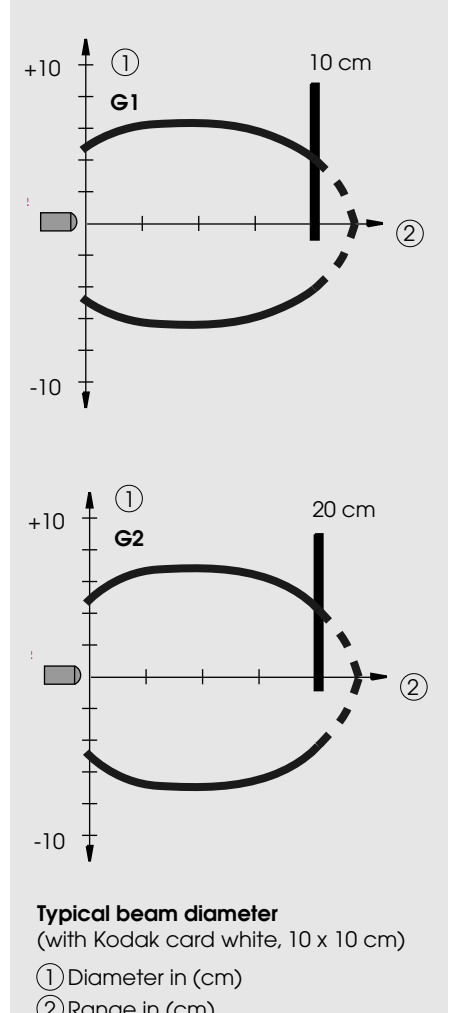

Wiring diagram

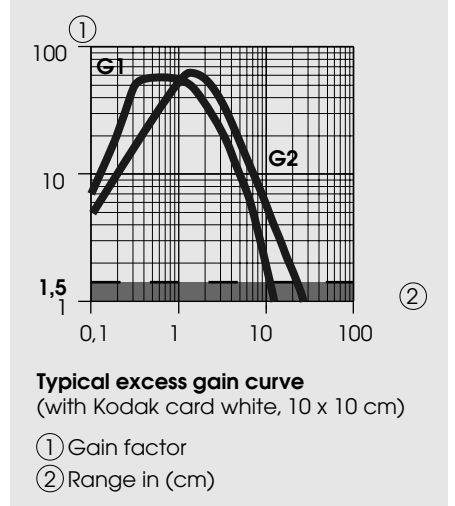
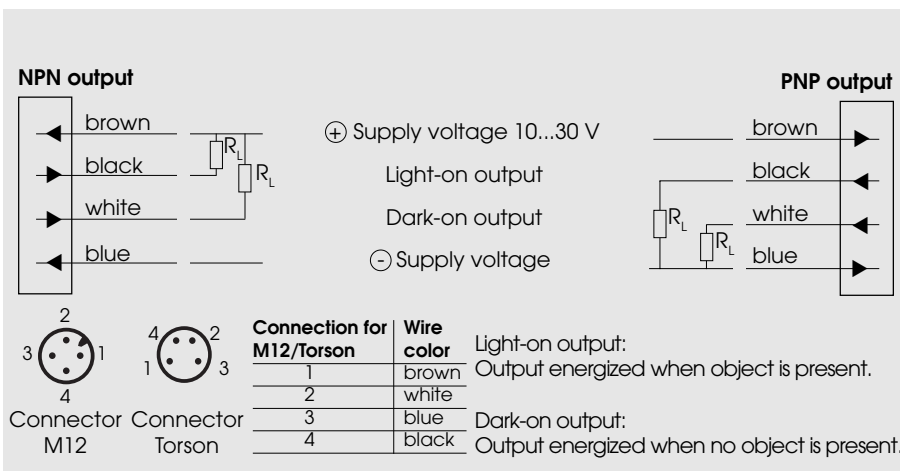

Diffuse-reflective sensors, range 40/65 cm, straight optics, M18 housing



- Combined surface and bore mounting
- Light reserve warning indicator
- Dual transistor outputs, NPN or PNP
- 1000 Hz switching frequency
- Short-circuit protection, reverse polarity protection, and power-up output suppression
- Connections: Straight cable, 2 meter
Connector, M12
Right angle cable, 2 meter (option)
Connector, Torson (option)
- EMC tested according to IEC 801 and EN50081-1/EN 50082-2



Product designation ¹⁾

Output

Connection

Range adjustment

Optical data ²⁾

Max. range

Emitter

Electrical data ²⁾

Supply voltage U_s

Allowable ripple

Current consumption (without load)

Max. load current I_L

Residual voltage

Max. switching frequency

Environmental data

Sealing

Temperature T_A
(operating and storage)

Weight

OMT 1NA 100 G3	OMT 1NA 400 G3	OMT 1PA 100 G3	OMT 1PA 400 G3	OMT 1NA 100 G4	OMT 1NA 400 G4	OMT 1PA 100 G4	OMT 1PA 400 G4
NPN (light-/dark-on)		PNP (light-/dark-on)		NPN (light-/dark-on)		PNP (light-/dark-on)	
Cable 2 m	Connector M12	Cable 2 m	Connector M12	Cable 2 m	Connector M12	Cable 2 m	Connector M12
Yes							
40 cm (Kodak card white, 10 x 10 cm)				65 cm (Kodak card white, 10 x 10 cm)			
Infrared-LED, 880 nm, pulsed							
10...30 VDC							
+/- 10% of U_s							
< 15 mA							
200 mA							
< 1,6 V							
1000 Hz							
IP 67							
-20...+90 °C (☛ Tech. explanation)							
ca. 90 g	ca. 20 g	ca. 90 g	ca. 20 g	ca. 90 g	ca. 20 g	ca. 90 g	ca. 20 g

1) For product designation of sensors with options see designation code on page 47.

2) When not otherwise noted, all technical data at $T_A = 25\text{ °C}$ and $U_s = 24\text{ V}$.

Technical explanation

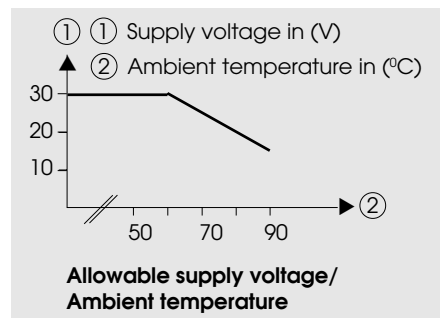

Allowable supply voltage as a function of ambient temperature

The specified operating temperature is only usable if the supply voltage is reduced at higher temperatures (☛ Diagram "Allowable supply voltage/Ambient temperature").

10...30 VDC

NPN / PNP
light-on and
dark-on output

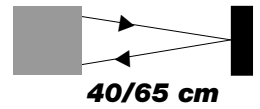

OMT straight optics

Dimensions (62,5 mm, M18 x 1)

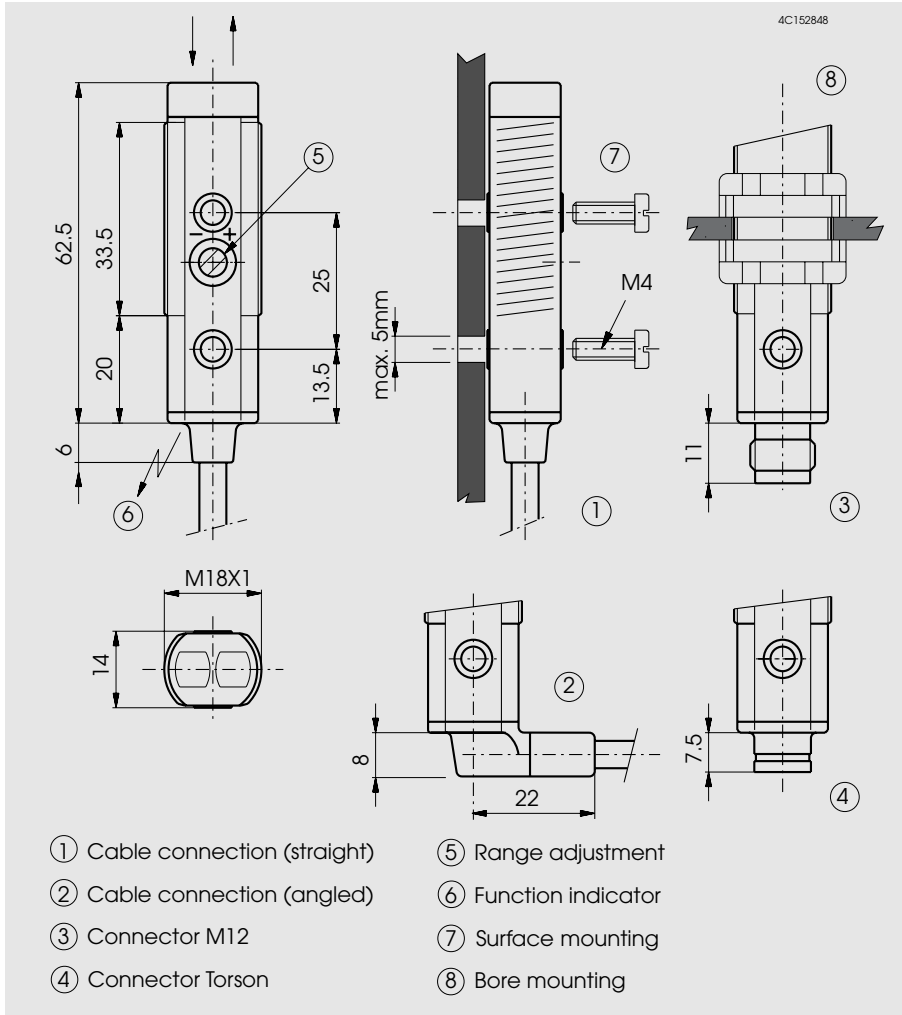

Optical diagrams

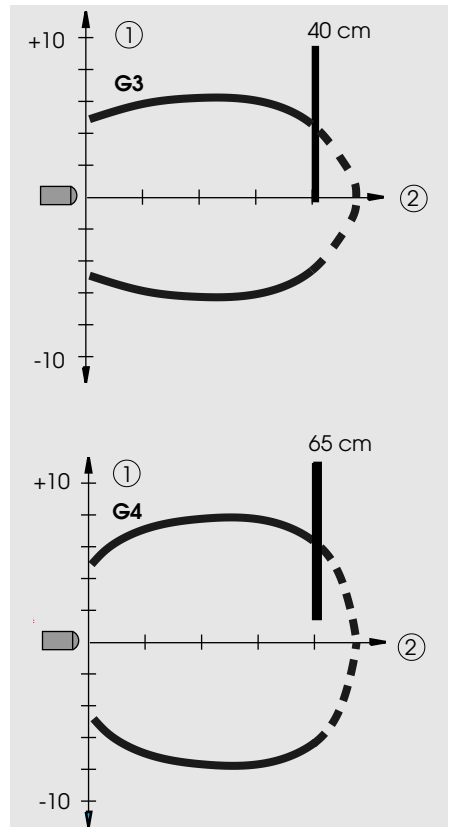

Typical beam diameter

(with Kodak card white, 10 x 10 cm)

① Diameter in (cm)

② Range in (cm)

Wiring diagram

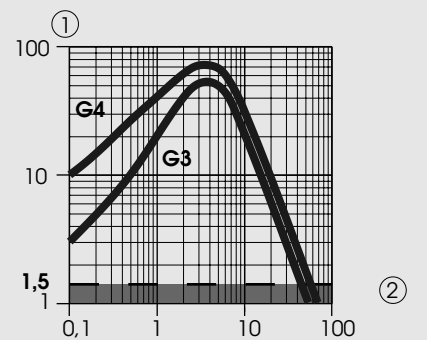
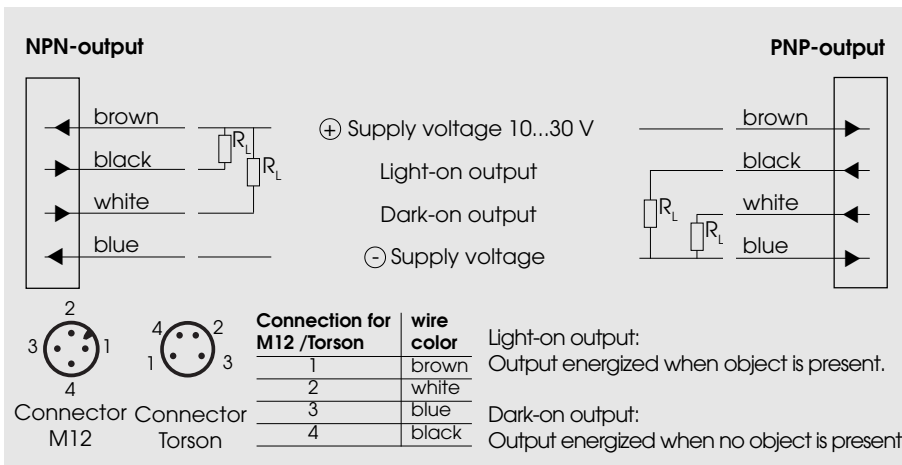

Typical excess gain curve

(with Kodak card white, 10 x 10 cm)

① Gain factor

② Range in (cm)

Diffuse-reflective sensors, range 10/40 cm, right angle optics, M18 housing



- Combined surface and bore mounting
- Light reserve warning indicator
- Dual transistor outputs, NPN or PNP
- 1000 Hz switching frequency
- Short-circuit protection, reverse polarity protection, and power-up output suppression
- Connections: Straight cable, 2 meter
Connector, M12
Right angle cable, 2 meter (option)
Connector, Torson (option)
- EMC tested according to IEC 801 and EN50081-1/EN 50082-2



Product designation ¹⁾

Output
Connection
Range adjustment
Optical data ²⁾
Max. range
Emitter
Electrical data ²⁾
Supply voltage U_s
Allowable ripple
Current consumption (without load)
Max. load current I_L
Residual voltage
Max. switching frequency
Environmental data
Sealing
Temperature T_A (operating and storage)
Weight

OMT 1NA 100 W1	OMT 1NA 400 W1	OMT 1PA 100 W1	OMT 1PA 400 W1	OMT 1NA 100 W3	OMT 1NA 400 W3	OMT 1PA 100 W3	OMT 1PA 400 W3
NPN (light-/dark-on)		PNP (light-/dark-on)		NPN (light-/dark-on)		PNP (light-/dark-on)	
Cable 2 m	Connector M12	Cable 2 m	Connector M12	Cable 2 m	Connector M12	Cable 2 m	Connector M12
Yes							
10 cm (Kodak card white, 10 x 10 cm)				40 cm (Kodak card white, 10 x 10 cm)			
Infrared-LED, 880 nm, pulsed							
10...30 VDC							
+/- 10% of U_s							
< 15 mA							
200 mA							
< 1,6 V							
1000 Hz							
IP 67							
-20...+90 °C (☛ Tech. explanation)							
ca. 95 g	ca. 25 g	ca. 95 g	ca. 25 g	ca. 95 g	ca. 25 g	ca. 95 g	ca. 25 g

1) For product designation of sensors with options see designation code on page 47.
2) When not otherwise noted, all technical data at $T_A = 25\text{ °C}$ and $U_s = 24\text{ V}$.

Technical explanation

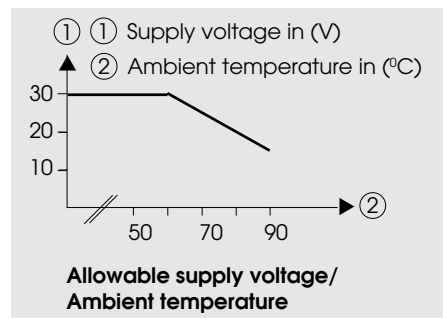

Allowable supply voltage as a function of ambient temperature

The specified operating temperature is only usable if the supply voltage is reduced at higher temperatures (☛ Diagram "Allowable supply voltage/Ambient temperature").

10...30 VDC

NPN / PNP
light-on and
dark-on output

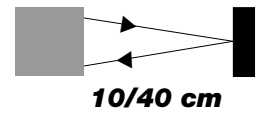

OMT right angle optics

Dimensions (71,5 mm, M18 x 1)

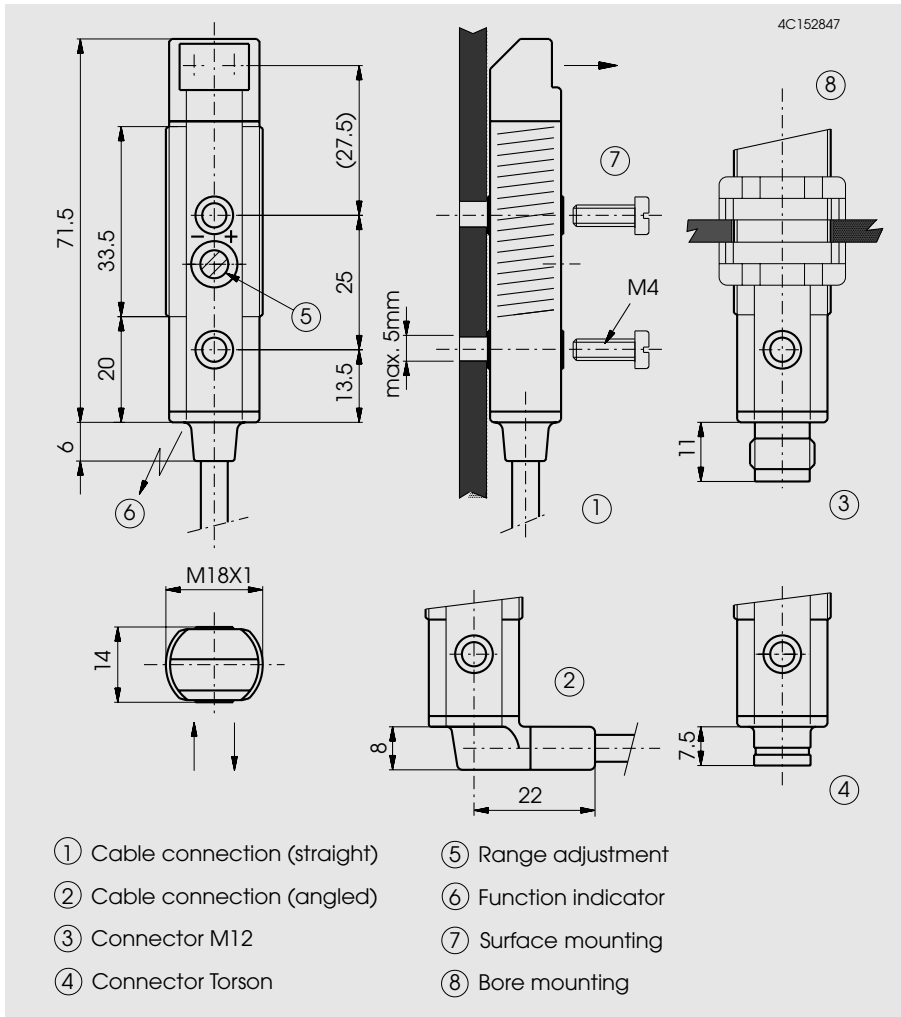

Optical diagrams

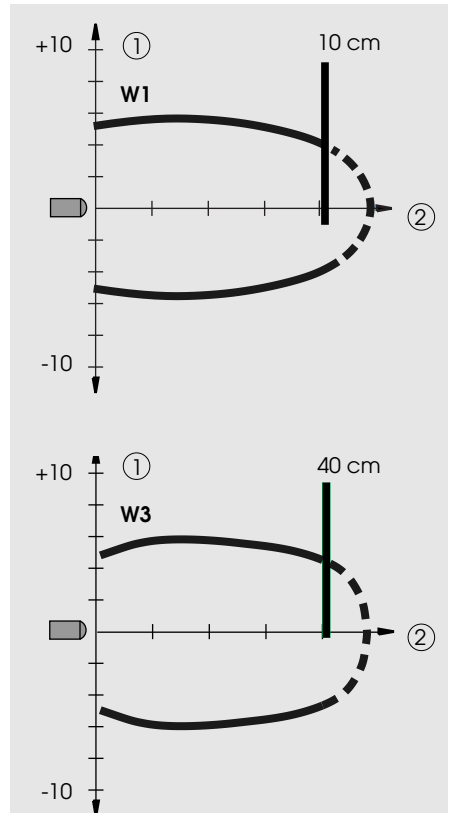

Typical beam diameter
(with Kodak card white, 10 x 10 cm)

- ① Diameter in (cm)
- ② Range in (cm)

Wiring diagram

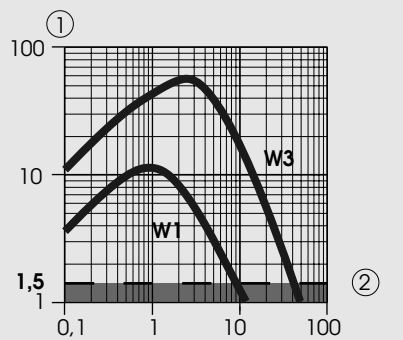
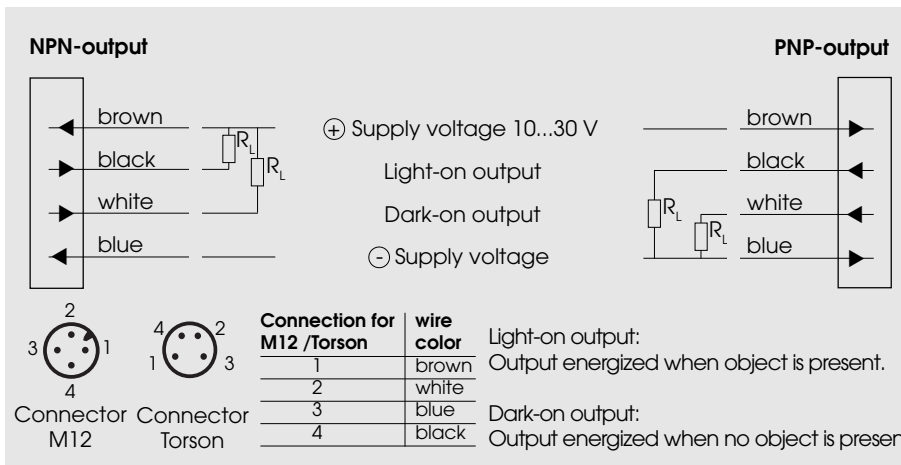

Typical excess gain curve
(with Kodak card white, 10 x 10 cm)

- ① Gain factor
- ② Range in (cm)

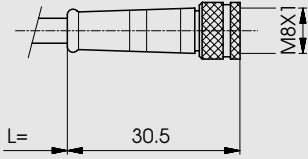

Straight, threaded connector M8, 4 pin

Product designation	Cable length
OZK 341 A 002	2 m
OZK 341 A 010	10 m

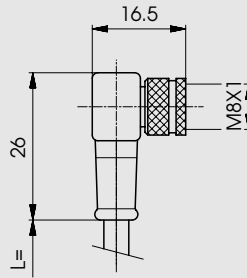

Right angle, threaded connector M8, 4 pin

Product designation	Cable length
OZK 342 A 002	2 m
OZK 342 A 010	10 m

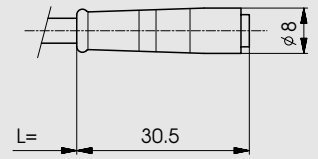

Straight, 2 m, snap-on connector M8

Product designation	Cable length
OZK 333 A 002	3 pin
OZK 343 A 002	4 pin

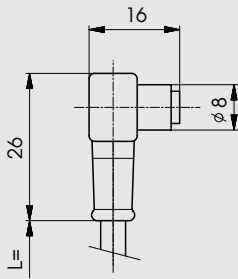

Right angle, snap-on connector M8, 4 pin

Product designation	Cable length
OZK 344 A 002	2 m
OZK 344 A 010	10 m

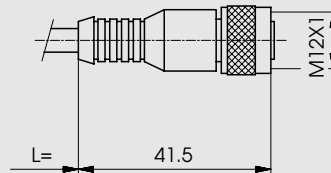

Straight, threaded connector M12, 4 pin

Product designation	Cable length
OZK 241 A 002	2 m
OZK 241 A 010	10 m

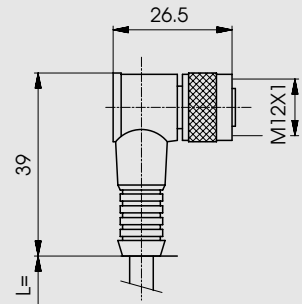

Right angle, threaded connector M12, 4 pin

Product designation	Cable length
OZK 242 A 002	2 m
OZK 242 A 010	10 m

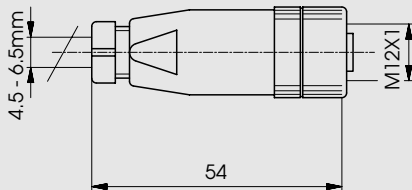

Self confectioning, straight, threaded connector M12, 4 pin

Product designation
OZK 248 A 000

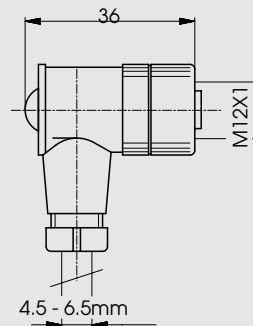

Self confectioning, right angle, threaded connector M12, 4 pin

Product designation
OZK 249 A 000

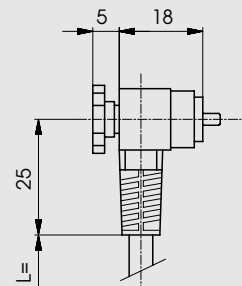

Right angle, Torson connector 4 pin

Product designation	Cable length
OZK 442 A 002	2 m
OZK 442 A 006	6 m
OZK 442 A 010	10 m

Fiber optic sensors OMT for glass fiber optics



- Combined surface and bore mounting
- Light reserve warning indicator
- Dual transistor outputs, NPN or PNP
- 1000 Hz switching frequency
- Short-circuit protection, reverse polarity protection, and power-up output suppression
- Connections: Cable, 2 meter
Connector, M12
Right angle cable, 2 meter cable, (option)
Connector, Torson (option)
- EMC tested according to IEC 801 and EN50081-1/EN 50082-2



Product designation¹⁾

Output

Connection

Range adjustment

Optical data²⁾

Range

Emitter

Electrical data²⁾

Supply voltage U_s

Allowable ripple

Current consumption (without load)

Max. load current I_L

Residual voltage

Max. switching frequency

Environmental data

Sealing

Temperature T_A
(operating and storage)

Weight

OMT 1NA 100 G2	OMT 1NA 400 G2	OMT 1PA 100 G2	OMT 1PA 400 G2
NPN (light- and dark-on)		PNP (light- and dark-on)	
Cable 2 m	Connector M12	Cable 2 m	Connector M12
Yes			
depends on the selected fiber optic cable			
Infrared LED, 880 nm, pulsed			
		10...30 VDC	
		+/- 10% of U_s	
		< 15 mA	
		200 mA	
		< 1,6 V	
		1000 Hz	
IP 67			
-20...+90 °C (☛ Tech. explanation)			
ca. 90 g	ca. 20 g	ca. 90 g	ca. 20 g

1) For product designation of sensors with options see designation code on page 47.

2) When not otherwise noted, all technical data at $T_A = 25\text{ °C}$ and $U_s = 24\text{ V}$.

Technical explanation

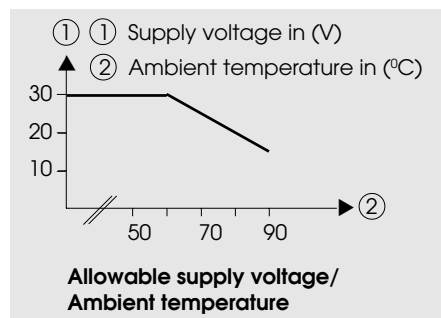

Allowable supply voltage as a function of ambient temperature

The specified operating temperature is only usable if the supply voltage is reduced at higher temperatures (☛ Diagram "Allowable supply voltage/Ambient temperature").

10...30 VDC

NPN / PNP
light-on and
dark-on output

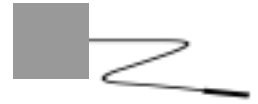

OMT

Dimensions (59 mm, M18 x 1)

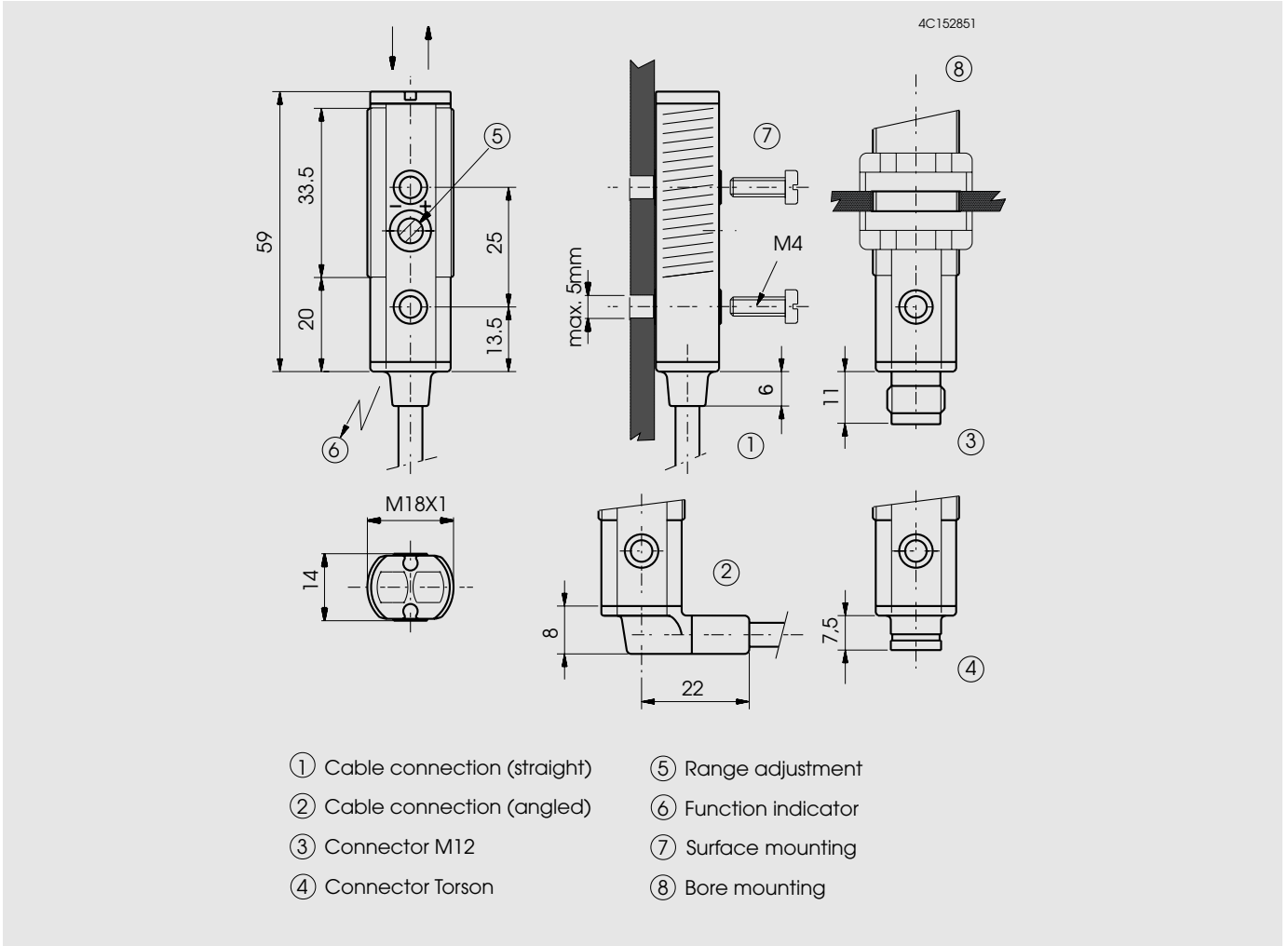

Wiring diagram

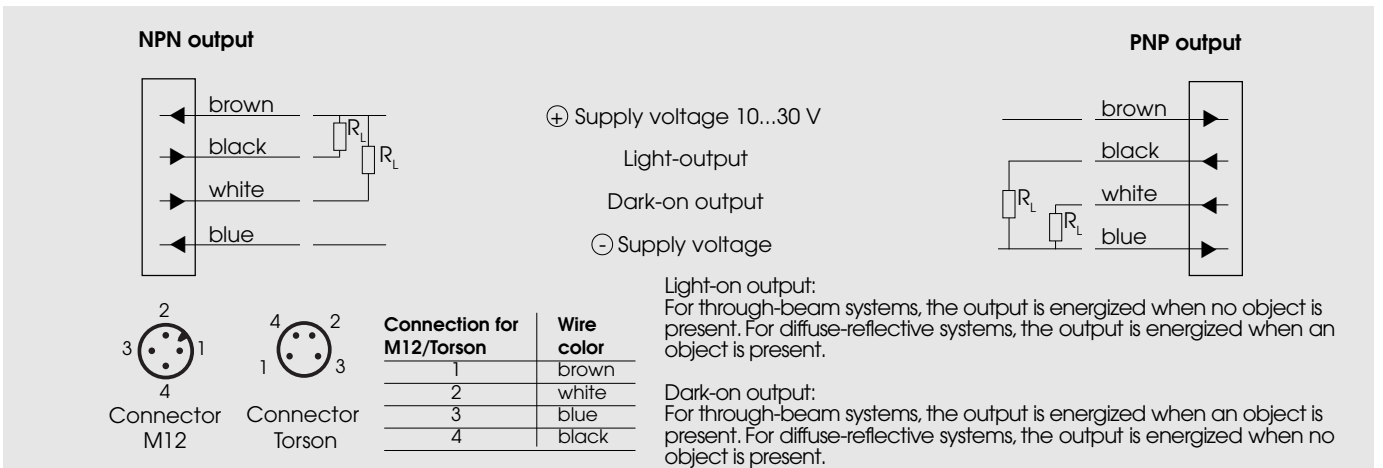

Dimensions

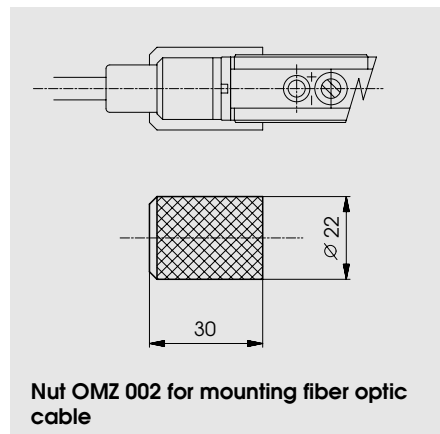
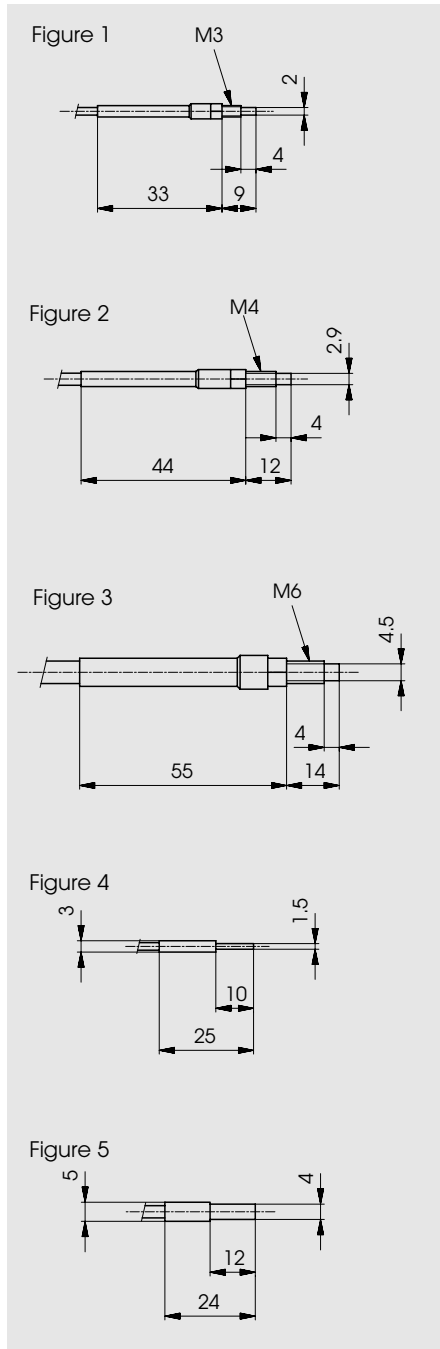

Through-beam

Fig.	Sensing head	Sheathing material	Cross section	Length	Range	Product designation
1	Threaded M3	Plastic (-25...+80 °C)	2 x 1 mm ²	50 cm	70 mm	OZL 112 A 251
1	Threaded M3	Plastic (-25...+80 °C)	2 x 1 mm ²	100 cm	40 mm	OZL 112 A 351
2	Threaded M4	Plastic (-25...+80 °C)	2 x 4 mm ²	50 cm	200 mm	OZL 116 A 252
2	Threaded M4	Plastic (-25...+80 °C)	2 x 4 mm ²	100 cm	150 mm	OZL 116 A 352
4	Ferruled 1,5 mm	Plastic (-25...+80 °C)	2 x 1 mm ²	50 cm	120 mm	OZL 112 A 240
5	Ferruled 4 mm	Plastic (-25...+80 °C)	2 x 4 mm ²	50 cm	200 mm	OZL 116 A 242
2	Threaded M4	Metal (-25...+250 °C)	2 x 4 mm ²	50 cm	200 mm	OZL 216 A 252

Diffuse-reflective

Fig.	Sensing head	Sheathing material	Cross section	Length	Range ¹⁾	Product designation
1	Threaded M3	Plastic (-25...+80 °C)	2 x 0,5 mm ²	50 cm	4 mm	OZL 141 A 251
2	Threaded M4	Plastic (-25...+80 °C)	2 x 1 mm ²	50 cm	7 mm	OZL 142 A 252
2	Threaded M4	Plastic (-25...+80 °C)	2 x 1 mm ²	100 cm	6 mm	OZL 142 A 352
3	Threaded M6	Plastic (-25...+80 °C)	2 x 4 mm ²	50 cm	40 mm	OZL 146 A 254
3	Threaded M6	Plastic (-25...+80 °C)	2 x 4 mm ²	100 cm	32 mm	OZL 146 A 354
4	Ferruled 1,5 mm	Plastic (-25...+80 °C)	2 x 0,5 mm ²	50 cm	4 mm	OZL 141 A 240
3	Threaded M6	Metal (-25...+250 °C)	2 x 4 mm ²	50 cm	40 mm	OZL 246 A 254

1) Measured with Kodak card white, 10 x 10 cm

Important mounting instructions:

These glass fiber optic cables are only for use with fiber optic sensor OMT.

Do not bend the glass optic cables sharply. The bending radius may not be smaller than three times the sheathing diameter. Do not subject the fiber optic cables to mechanical forces (i.e. pulling, pressure, or twisting). The light emitting surfaces must also be protected from mechanical damage.

***ELESTA fiber optic sensors in use
in an automated assembly machine***

