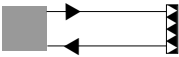
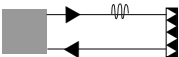

Series OG

**Strong – refined –
the bulls for the vision in automation**

 50 m
Through-beam sensors OGS/OGE

 up to 32 m
Retro-reflective sensors OGR

 up to 18 m
Retro-reflective sensors
with polarizing filters OGP

 1,8 m
Diffuse-reflective sensors OGT

 0,2...0,8 m
Diffuse-reflective sensors
with background rejection OGH



High functionality

Diverse principles with large ranges

ELESTA's OG sensors are available as through-beam sensors, retro-reflective sensors with and without polarizing filters, as well as diffuse-reflective sensors. Additionally, diffuse-reflective sensors with background rejection are available.

Light reserve warning indicator
All of the sensors in the OG series contain a light-reserve warning indicator (blinking function indicator) for controlling dirt build-up on the lenses and as an alignment aid.

Low power consumption

The OG sensors distinguish themselves with an extremely small power consumption.

DC (10-30V) sensors, dual output, NPN or PNP

All DC sensors have a 1000 Hz switching frequency, allowing for the reliable detection of even fast moving objects. As an option, DC sensors are available with a test input, for confirming that the sensor is operating properly. Sensors with test input have only one output, either light-on or dark-on.

AC/DC (24-240V) sensors with relay output

All AC/DC sensors provide a galvanically isolated relay output with a change-over contact (1CO). The output is light-on activated (relay is energized when the receiver detects light from the emitter).

Simple installation and operation

Adjustable range

The optical range of each OG sensor can be adjusted to meet the specific application.

Highly visible function indicator LED

The LED indicator is visible from the front, back, and top.

Simple mounting

For easy mounting all OG sensors have two slots at the bottom side for M5 nuts, as well as two bores for 5 mm self-tapping screws.

M12 connector or cable output, rotatable

The OG sensors are available standard with a 2m cable or a M12 connector. The cable or connector outlets can be rotated in 90° steps. A mechanical stop prevents overwinding. These sensors are thereby adaptable to a variety of applications, irrespective of space and mounting limitations.

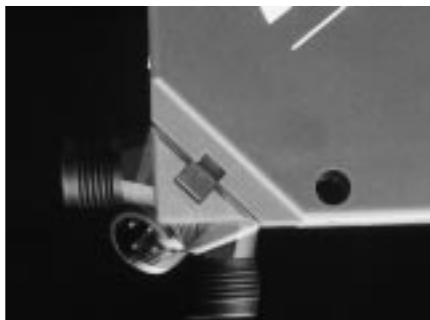

Reliable for the highest demands

Robust construction, glass protected optics

The OG photoelectric sensors are built with a glass-sphere reinforced polyamide housing. A glass window protects the optics against aggressive chemicals and mechanical damage (scratching).

IP 67 sealing

All OG sensors meet the water and dust sealing requirements of IP 67.

EMC-tested

The OG sensors are tested according to IEC 801, EN50081-2 and EN50082-2. This assures trouble free use even in high electromagnetically contaminated environments.

High ambient light rejection

Thanks to pulse modulation and a multilevel disturbance rejection, the OG sensors are extremely insensitive to foreign light sources.

Reverse polarity protection

All of the DC sensor's electrical connections are protected against reverse wiring.

Short-circuit protection

The OG sensor's transistor outputs are electronically protected against short circuit.

Power-up output suppression

During power-up the outputs of the OG sensors are blocked for typically 30 msec.

Designation code

OG X XXX XXX XX

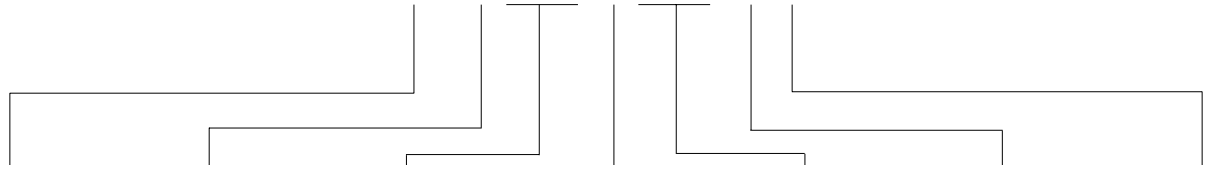

Principle	Supply	Outputs	Connection	Electr. option	Light	Range
E: Through-beam receiver	1: DC 10-30 V	KA: No output	0: Cable special length	00: Range adjustable	I: Infrared	OGS/OGE: 1: 50 m 2: 40 m
H: Diffuse-reflective with background rejection	7: AC/DC 24-240 V	NA: NPN light-and dark-on	1: Cable 2 m	01: Range adjustable, test input	R: Red	OGP/OGR: 1: 9 m 2: 18 m
P: Retro-reflective with polarizing filters		ND: NPN dark-on	4: Connector M12	40: Range not adjustable	Q: Red ± 2°	OGT/OGH: 1: 1,8 m 2: 0,8 m
R: Retro-reflective		NH: NPN light-on		41: Range not adjustable, test input		
S: Through-beam emitter		PA: PNP light-and dark-on				
T: Diffuse-reflective		PD: PNP dark-on				
Z: Accessory		PH: PNP light-on				
		HW: Relay output, light-on, 1 CO contact				

Accessories

Retroreflectors: see page 130

Connector cables: see page 128

Mounting:

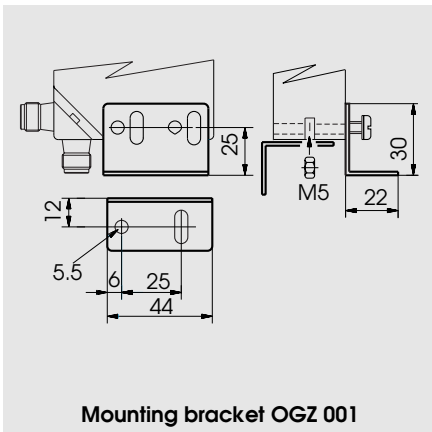

Mounting bracket OGZ 001

Through-beam sensors, in a robust plastic housing



- DC or AC/DC supply voltage
- Short-circuit protected dual transistor outputs (**NPN oder PNP**) or relay output with 1 change over contact
- Reverse polarity protection **and** power-up output suppression
- Light reserve warning indicator
- Test input on DC sensors
- Versions with red light and beam angle $< \pm 2^\circ$ available
- Cable 2 m or connector M12, rotatable
- EMC tested according to IEC 801 and EN 50081-2/EN 50082-2



Product designation ¹⁾

Output
Connection
Range adjustment

Optical data ²⁾

Max. range
Emitter

Electrical data ²⁾

Supply voltage U_s
Allowable ripple
Current consumption (without load)
Max. load current I_L
Residual voltage
Max. switching frequency
Test input: emitter on emitter off

Environmental data

Sealing
Temperature T_A (operating and storage)
Weight

Emitter		Receiver				Emitter	Receiver
OGS 1KA 141 I1	OGS 1KA 441 I1	OGE 1NA 100 I1	OGE 1NA 400 I1	OGE 1PA 100 I1	OGE 1PA 400 I1	OGS 7KA 140 I1	OGE 7HW 100 I1
		NPN (light-/dark-on)		PNP (light-/dark-on)			Relay
Cable 2 m	Connector M12	Cable 2 m	Connector M12	Cable 2 m	Connector M12	Cable 2 m	
No		Yes				No	Yes
50 m							
Infrared-LED 880 nm, pulsed						Infrared-LED 880 nm, pulsed	
10...30 VDC						24...240 VAC/DC	
+/-10% of U_s							
< 25 mA		< 15 mA				< 2 VA	
		200 mA				2A	
		< 1,6 V					
		1000 Hz				25 Hz	
+ U_s or open < 1 V							
IP 67							
-25...+65 °C							
ca. 140 g	ca. 100 g	ca. 140 g	ca. 100 g	ca. 140 g	ca. 100 g	ca. 200 g	

1) For product designation of sensors with options see designation code on page 93.

2) When not otherwise noted, all technical data at $T_A = 25^\circ\text{C}$ and $U_s = 24\text{ VDC}$ or $U_s = 220\text{ VAC}$, respectively.

24...240 VAC/DC 10...30 VDC

Relay
1 CO contact

NPN / PNP
light-on and
dark-on output



50 m

OGS/OGE

Dimensions (68,5 mm x 67 mm x 30 mm)

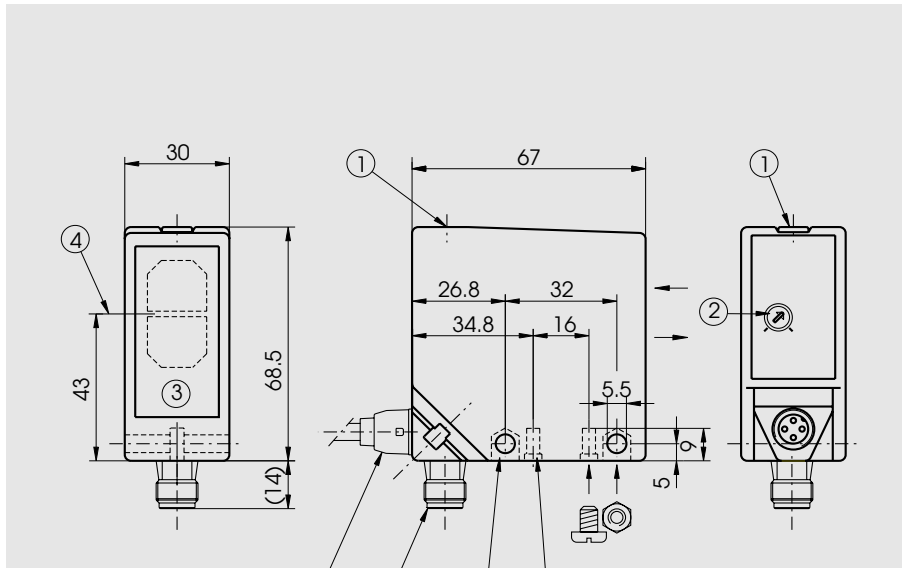

- ① Emitter: operation indicator
Receiver: function indicator
- ② Range adjustment
- ③ Glass covered optics
- ④ Center of the optical axis
- ⑥ Cable connection
- ⑦ Connector M12
- ⑧ Opening for M5 nut
- ⑨ Bore for 5 mm self-tapping screw

Optical diagrams

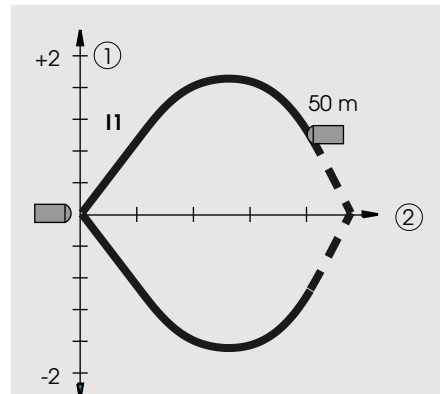

Typical beam diameter

- ① Diameter in (m)
- ② Range in (m)

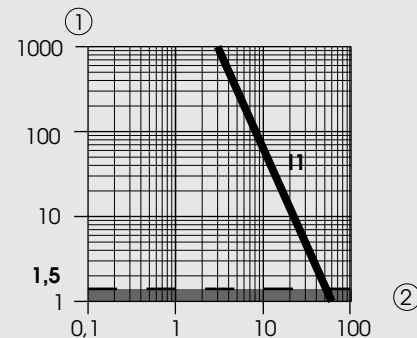

Typical excess gain curve

- ① Gain factor
- ② Range in (m)

Wiring diagram

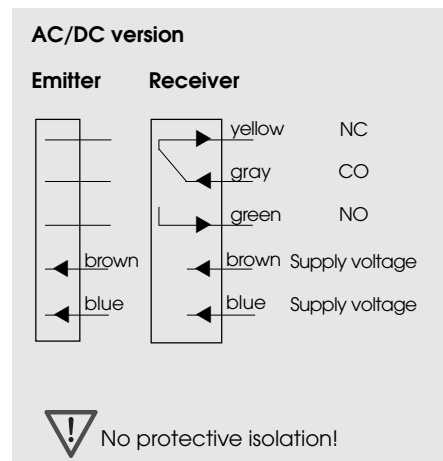
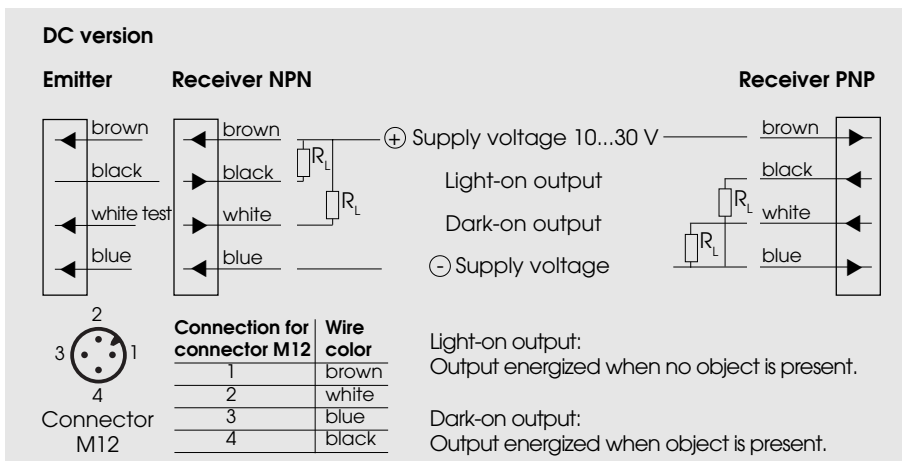

Retro-reflective sensors, in a robust plastic housing



- DC or AC/DC supply voltage
- Short-circuit protected dual transistor outputs (NPN oder PNP) or relay output with 1 change over contact
- Reverse polarity protection and power-up output suppression
- Light reserve warning indicator
- Test input (option on DC sensors)
- Cable 2 m or connector M12, rotatable
- EMC tested according to IEC 801 and EN 50081-2/EN 50082-2



Product designation ¹⁾

Output
Connection
Range adjustment

Optical data ²⁾

Range
Emitter

Electrical data ²⁾

Supply voltage U_s
Allowable ripple
Current consumption (without load)
Max. load current I_L
Residual voltage
Max. switching frequency

Environmental data

Sealing
Temperature T_A (operating and storage)
Weight

OGR 1NA 100 I2	OGR 1NA 400 I2	OGR 1PA 100 I2	OGR 1PA 400 I2	OGR 7HW 100 I2
NPN (light- and dark-on)		PNP (light- and dark-on)		Relay (light-on)
Cable 2 m	Connector M12	Cable 2 m	Connector M12	Cable 2 m
Yes				
0,3...18 m (retroreflector OZR 001)				
Infrared-LED, 890 nm, pulsed				
10...30 VDC			24...240 VAC/DC	
+/- 10% of U_s				
< 15 mA			< 2 VA	
200 mA			2 A	
< 1,6 V				
1000 Hz			25 Hz	
IP 67				
-25...+65 °C				
ca. 140 g	ca. 100 g	ca. 140 g	ca. 100 g	ca. 200 g

Option ¹⁾

Test input: emitter on
emitter off

+ U_s or open	
< 1 V	< $U_s - 8 V$

1) For product designation of sensors with options see designation code on page 93.

2) When not otherwise noted, all technical data at $T_A = 25 °C$ and $U_s = 24 VDC$ or $U_s = 220 VAC$, respectively.

Retro-reflector ●	Range	Retro-reflector ■	Range	Retro-reflective tape	Range
OZR 001	0.3 – 18 m	OZR 101	0.03 – 25 m	OZR 201*	0.4 – 6 m
OZR 002	0.4 – 16 m	OZR 102	0.3 – 9 m	OZR 202	0.6 – 13 m
OZR 003	0.4 – 8 m	OZR 103	0.4 – 20 m	OZR 203	0.5 – 11 m
		OZR 104	0.4 – 32 m	OZR 204*	0.5 – 11 m
				OZR 205*	0.5 – 15 m

* 30 cm long

24...240 VAC/DC

10...30 VDC

Relay
1 CO contact

NPN / PNP
light-on and
dark-on output

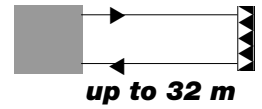

OGR

Dimensions (68,5 mm x 67 mm x 30 mm)

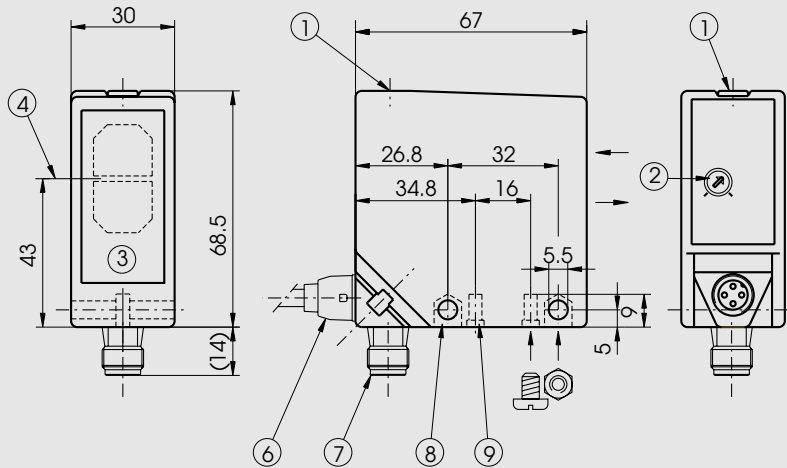

- ① Function indicator
- ② Range adjustment
- ③ Glass covered optics
- ④ Center of the optical axis
- ⑥ Cable connection
- ⑦ Connector M12
- ⑧ Opening for M5 nut
- ⑨ Bore for 5 mm self-tapping screw

Optical diagrams

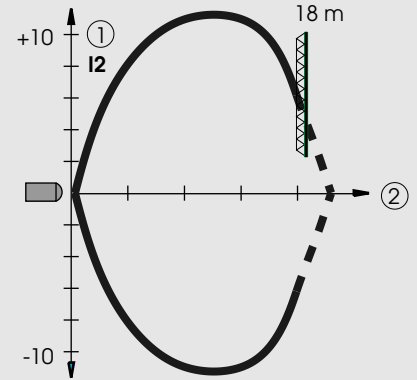

Typical beam diameter
(with retroreflector OZR 001)

- ① Diameter in (cm)
- ② Range in (m)

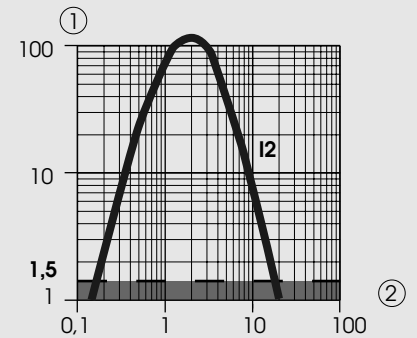

Typical excess gain curve
(with retroreflector OZR 001)

- ① Gain factor
- ② Range in (m)

Wiring diagram

DC version

NPN output

PNP output

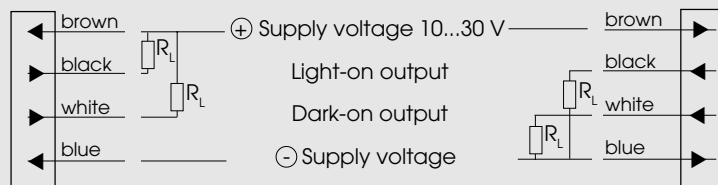

Connector M12	Connection for connector M12	Wire color	Connection for test input
1	Supply+	brown	Light-on output: Output energized when no object is present.
2	Test input	white	
3	Supply -	blue	Dark-on output: Output energized when object is present.
4	Output	black	

AC/DC version

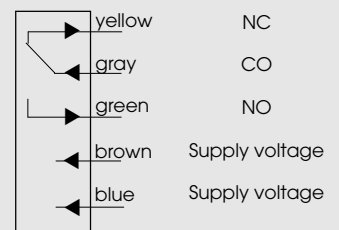

No protective isolation!

Retro-reflective sensors with polarizing filters, in a robust plastic housing



- DC or AC/DC supply voltage
- Short-circuit protected dual transistor outputs (NPN oder PNP) or relay output with 1 change over contact
- Reverse polarity protection and power-up output suppression
- Light reserve warning indicator
- Test input (option on DC sensors)
- Cable 2 m or connector M12, rotatable
- EMC tested according to IEC 801 and EN 50081-2/EN 50082-2



Product designation¹⁾

Output

Connection

Range adjustment

Optical data²⁾

Range

Emitter

Electrical data²⁾

Supply voltage U_s

Allowable ripple

Current consumption (without load)

Max. load current I_L

Residual voltage

Max. switching frequency

Environmental data

Sealing

Temperature T_A
(operating and storage)

Weight

OGP 1NA 100 R1	OGP 1NA 400 R1	OGP 1PA 100 R1	OGP 1PA 400 R1	OGP 7HW 100 R1
NPN (light- and dark-on)		PNP (light- and dark-on)		Relay (light-on)
Cable 2 m	Connector M12	Cable 2 m	Connector M12	Cable 2 m
Yes				
0,2...9 m (retroreflector OZR 001)				
Visible-red LED, 660 nm, pulsed, with polarizing filter				
10...30 VDC				24...240 VAC/DC
+/- 10% of U_s				
< 15 mA				< 2 VA
200 mA				2 A
< 1,6 V				
1000 Hz				25 Hz
IP 67				
-25...+65 °C				
ca. 140 g	ca. 100 g	ca. 140 g	ca. 100 g	ca. 200 g

Option¹⁾

Test input: emitter on

emitter off

+ U_s or open	
< 1 V	< U_s - 8 V

1) For product designation of sensors with options see designation code on page 93.

2) When not otherwise noted, all technical data at $T_A = 25$ °C and $U_s = 24$ VDC or $U_s = 220$ VAC, respectively.

Retro-reflector ●	Range	Retro-reflector ■	Range	Retro-reflective tape	Range
OZR 001	0.20 – 9 m	OZR 101	0.10 – 15 m	OZR 201	0 m
OZR 002	0.15 – 8 m	OZR 102	0.15 – 5 m	OZR 202	0 m
OZR 003	0.20 – 4 m	OZR 103	0.10 – 11 m	OZR 203	0.40 – 4.5 m
		OZR 104	0.10 – 18 m	OZR 204*	0.40 – 3.9 m
				OZR 205*	0.40 – 5.4 m

* 30 cm long

24...240 VAC/DC

10...30 VDC

Relay
1 CO contact

NPN / PNP
light-on and
dark-on output

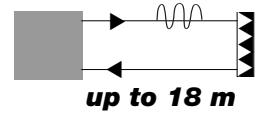

OGP

Dimensions (68,5 mm x 67 mm x 30 mm)

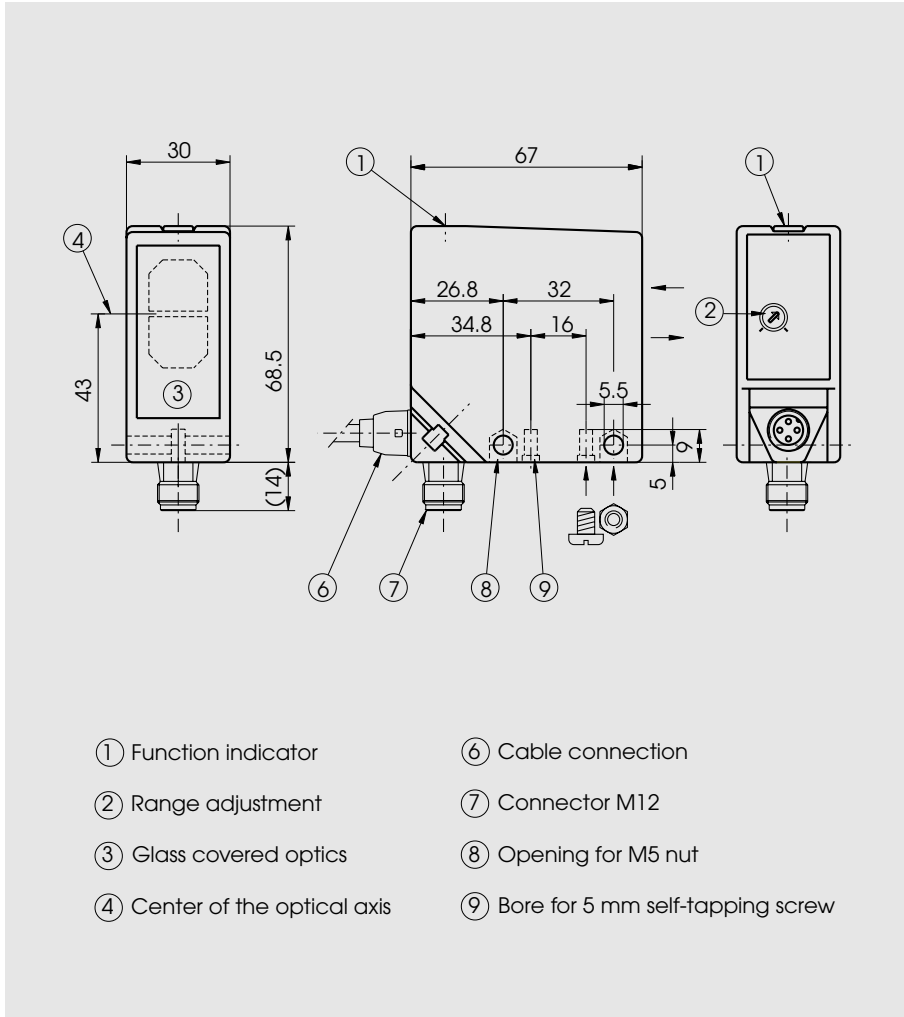

Optical diagrams

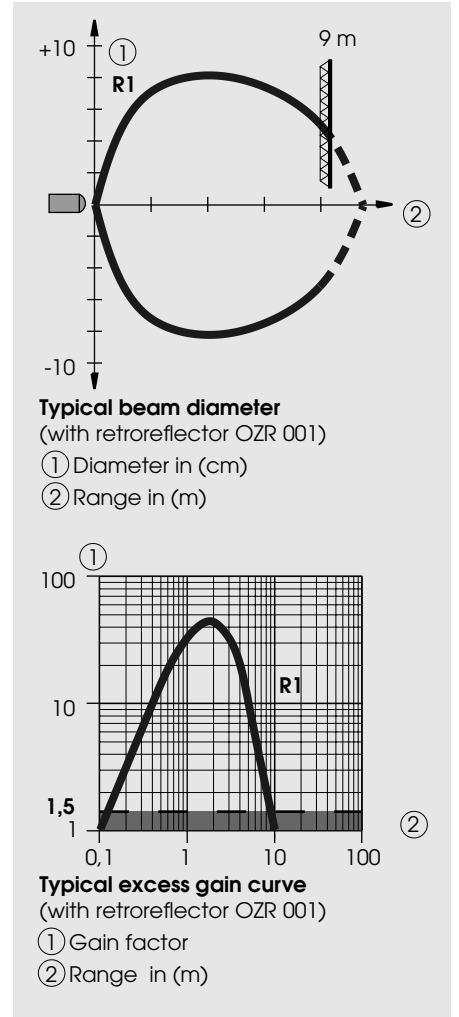

Wiring diagram

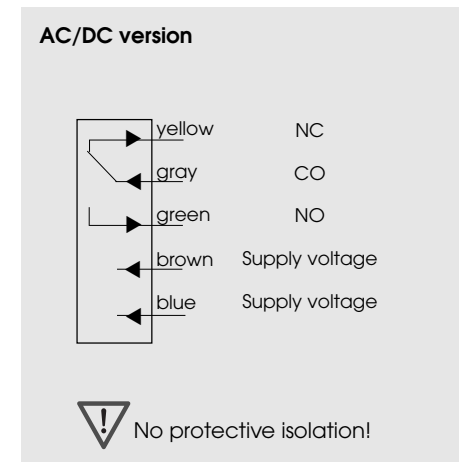
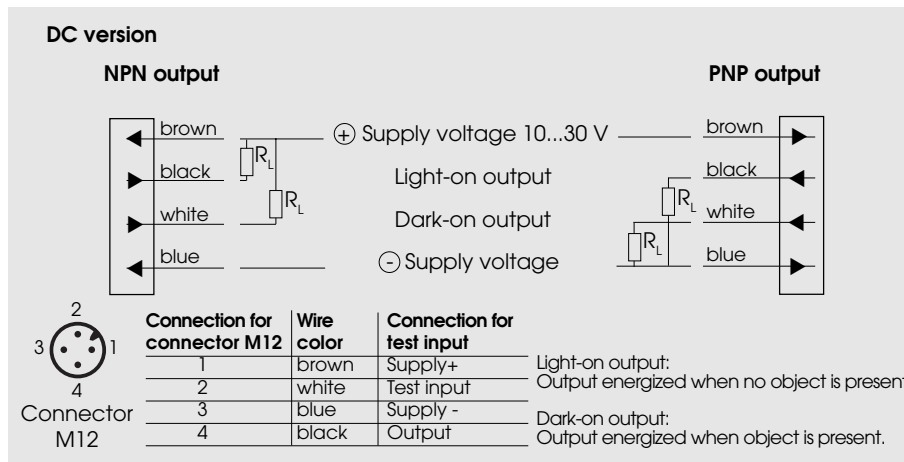

Diffuse-reflective sensors, in a robust plastic housing



- DC or AC/DC supply voltage
- Short-circuit protected dual transistor outputs (NPN oder PNP) or relay output with 1 change over contact
- Reverse polarity protection and power-up output suppression
- Light reserve warning indicator
- Cable 2 m or connector M12, rotatable
- EMC tested according to IEC 801 and EN 50081-2/EN 50082-2



Product designation ¹⁾	OGT 1NA 100 I1	OGT 1NA 400 I1	OGT 1PA 100 I1	OGT 1PA 400 I1	OGT 7HW 100 I1
Output	NPN (light- and dark-on)		PNP (light- and dark-on)		Relay (light-on)
Connection	Cable 2 m	Connector M12	Cable 2 m	Connector M12	Cable 2 m
Range adjustment	Yes				
Optical data ²⁾					
Max. range	1,8 m (Kodak card white, 20 x 20 cm)				
Emitter	Infrared-LED, 880 nm, pulsed				
Electrical data ²⁾					
Supply voltage U_s	10...30 VDC				24...240 VAC/DC
Allowable ripple	+/- 10% of U_s				
Current consumption (without load)	< 15 mA				< 2 VA
Max. load current I_L	200 mA				2 A
Residual voltage	< 1,6 V				
Max. switching frequency	1000 Hz				25 Hz
Environmental data					
Sealing	IP 67				
Temperature T_A (operating and storage)	-25...+65 °C				
Weight	ca. 140 g	ca. 100 g	ca. 140 g	ca. 100 g	ca. 200 g

1) For product designation of sensors with options see designation code on page 93.

2) When not otherwise noted, all technical data at $T_A = 25\text{ °C}$ and $U_s = 24\text{ VDC}$ or $U_s = 220\text{ VAC}$, respectively.

24...240 VAC/DC 10...30 VDC

Relay
1 CO contact

NPN / PNP
light-on and
dark-on output

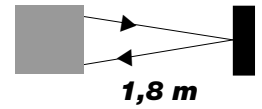

OGT

Dimensions (68,5 mm x 67 mm x 30 mm)

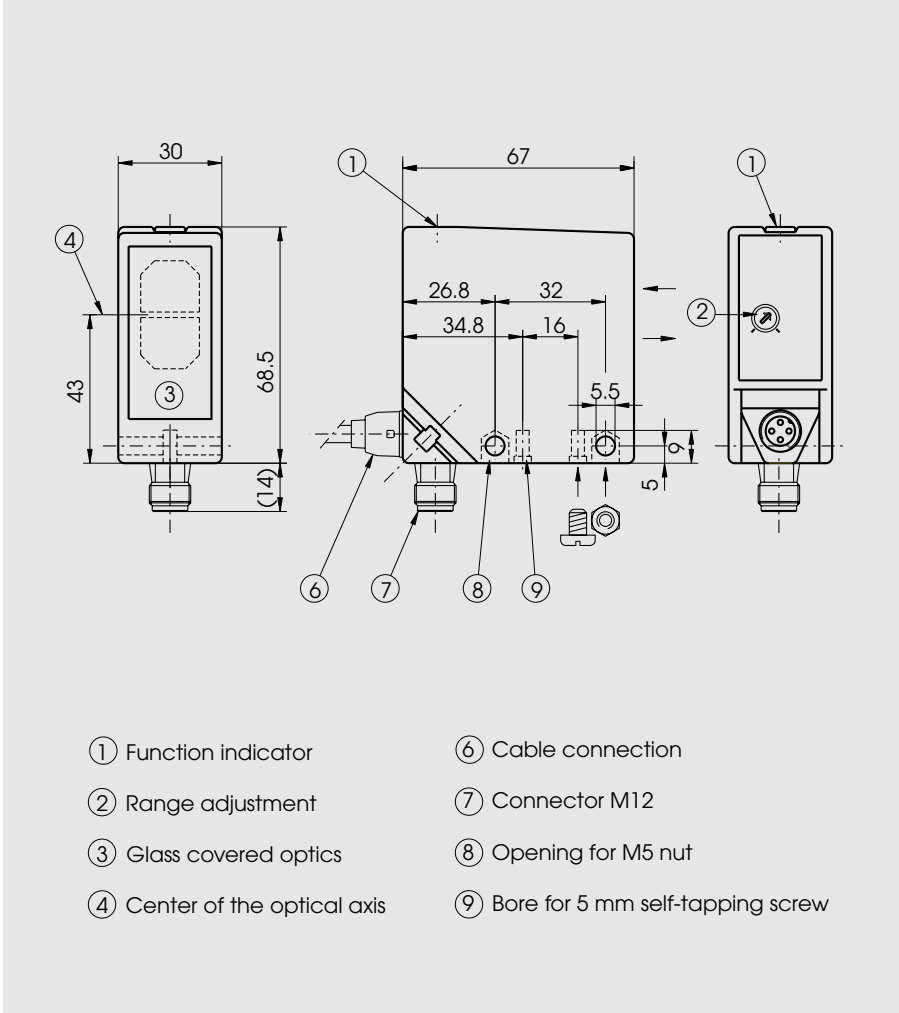

Optical diagrams

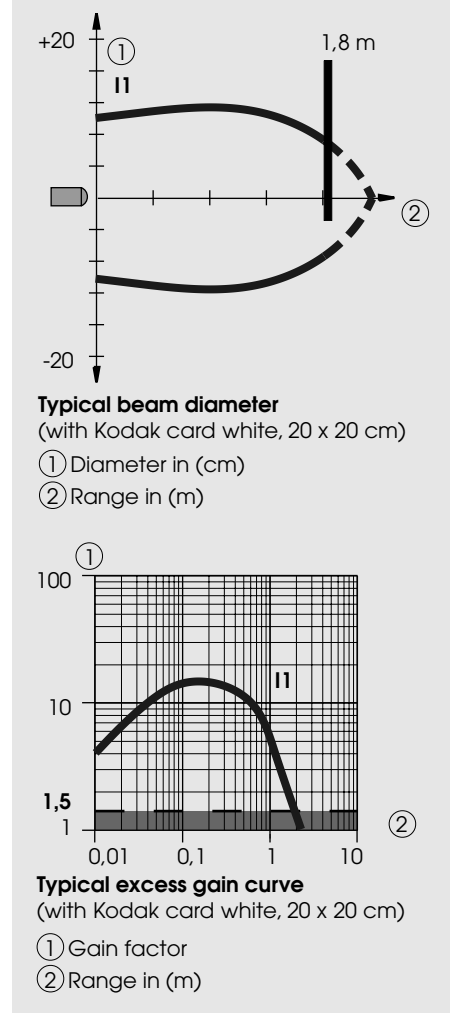

Wiring diagram

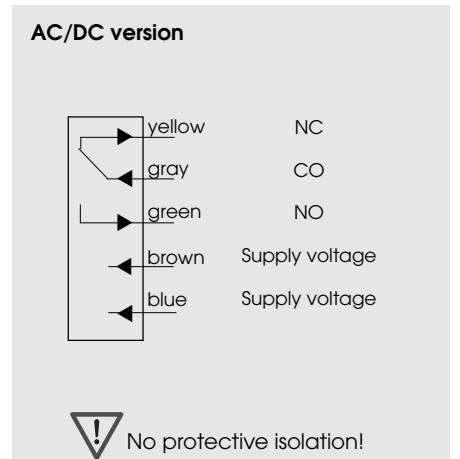
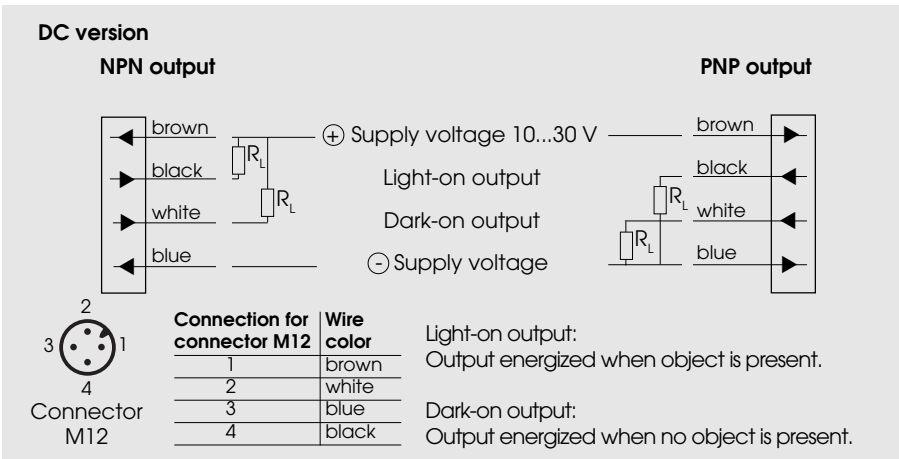

Diffuse-reflective sensors with background rejection, in a robust plastic housing



- DC or AC/DC supply voltage
- Short-circuit protected dual transistor outputs (NPN oder PNP) or relay output with 1 change over contact
- Reverse polarity protection and power-up output suppression
- Light reserve warning indicator
- Electronically adjustable background rejection
- Cable 2 m or connector M12, rotatable
- EMC tested according to IEC 801 and EN 50081-2/EN 50082-2



Product designation¹⁾

Output

Connection

Range adjustment

Optical data²⁾

Range

Emitter

Electrical data²⁾

Supply voltage U_s

Allowable ripple

Current consumption (without load)

Max. load current I_L

Residual voltage

Max. switching frequency

Environmental data

Sealing

Temperature T_A
(operating and storage)

Weight

	OGH 1NA 100 I2	OGH 1NA 400 I2	OGH 1PA 100 I2	OGH 1PA 400 I2	OGH 7HW 100 I2
Output	NPN (light- and dark-on)		PNP (light- and dark-on)		Relay (light-on)
Connection	Cable 2 m	Connector M12	Cable 2 m	Connector M12	Cable 2 m
Range adjustment	Yes				
Range	0,2...0,8 m (Kodak card white, 10 x 10 cm)				
Emitter	Infrared-LED, 880 nm, pulsed				
Supply voltage U_s	10...30 VDC				24...240 VAC/DC
Allowable ripple	+/- 10% of U_s				
Current consumption (without load)	< 35 mA				< 2 VA
Max. load current I_L	200 mA				2 A
Residual voltage	< 1,6 V				
Max. switching frequency	200 Hz				25 Hz
Sealing	IP 67				
Temperature T_A (operating and storage)	-25...+65 °C				
Weight	ca. 170 g	ca. 130 g	ca. 170 g	ca. 130 g	ca. 230 g

1) For product designation of sensors with options see designation code on page 93.

2) When not otherwise noted, all technical data at $T_A = 25\text{ °C}$ and $U_s = 24\text{ VDC}$ or $U_s = 220\text{ VAC}$, respectively.

Technical explanation

The 18%-linie shows the switching-on distance for a gray object.

The 90%-linie shows the switching-off distance for a white object.

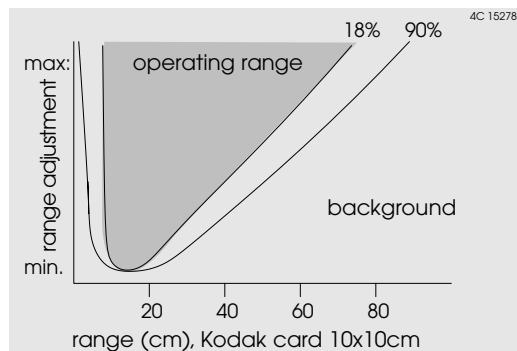

24...240 VAC/DC 10...30 VDC

Relay
1 CO contact

NPN / PNP
light-on and
dark-on output

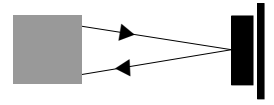

0,2...0,8 m

OGH

Dimensions (68,5 mm x 67 mm x 30 mm)

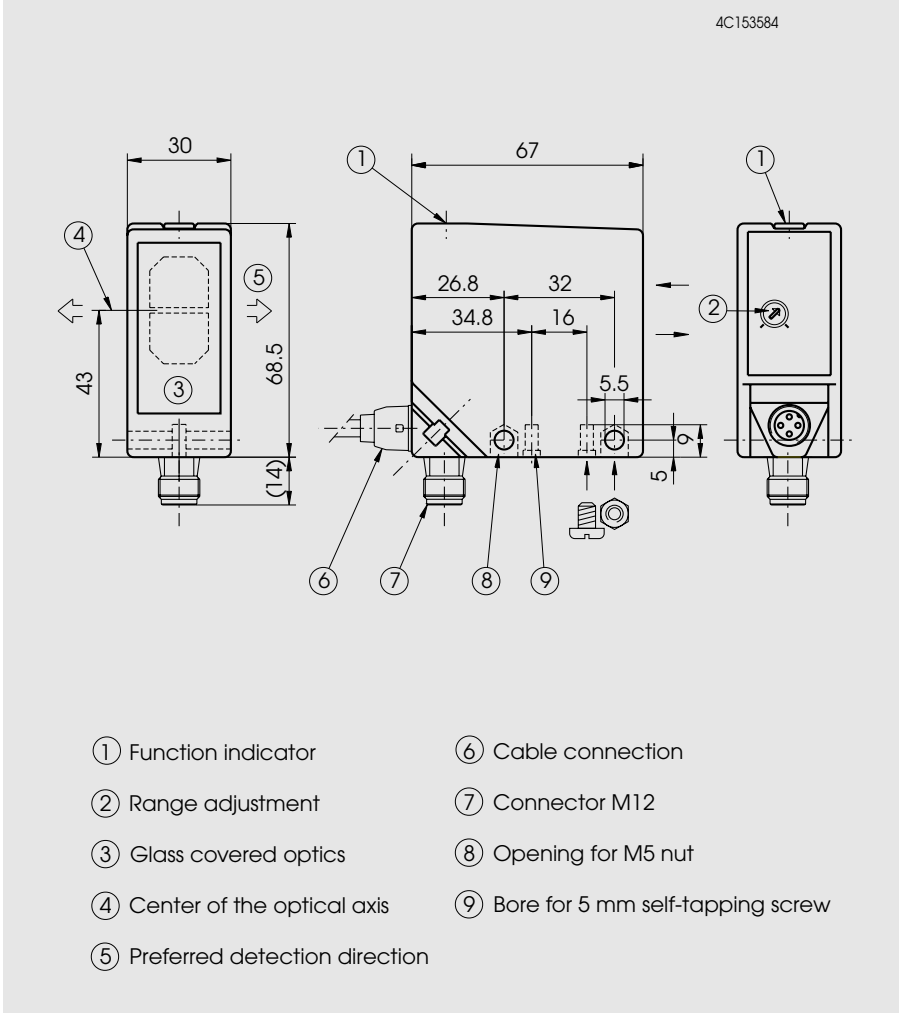

Optical diagrams

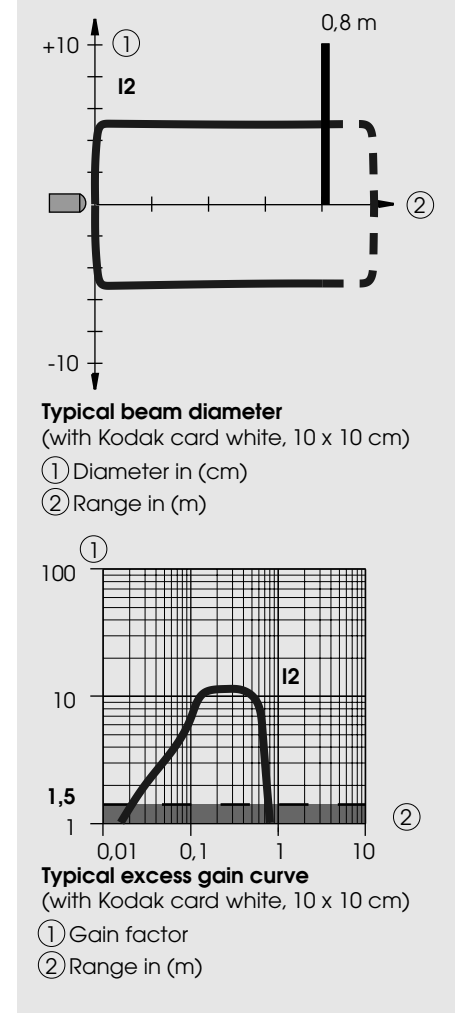

Wiring diagram

