

Series OF

Powerful – universal –
the giants for tireless performance

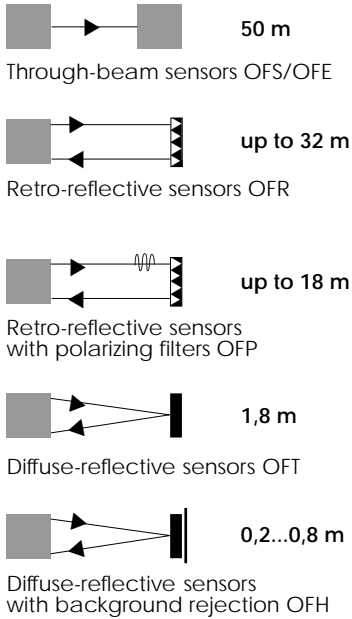

High functionality

Diverse principles with large ranges

ELESTA's OF sensors are available as through-beam sensors, retro-reflective sensors with and without polarizing filters, as well as diffuse-reflective sensors. Additionally, diffuse-reflective sensors with background rejection are available.

Light reserve warning indicator

All of the sensors in the OF series contain a *light-reserve warning indicator* (blinking function indicator) for controlling dirt build-up on the lenses and as an *alignment aid*.

DC (10-30V) sensors, dual output, NPN or PNP

All DC sensors have a 1000 Hz switching frequency, allowing for the reliable detection of even fast moving objects. As an option, DC sensors are available with a *test input*, to confirm proper operation, and/or with a *light reserve warning output* (static or dynamic, NO or NC), for remote monitoring of the light reserve.

AC/DC (24-240V) sensors with relay output

All AC/DC sensors provide a galvanically isolated relay output with a change over contact (1CO). The relay may be selected as either *light-* or *dark-on*, by use of a bridge connector.

As an option, the AC/DC sensors are available with an integrated timer module containing various timer functions.

Simple installation and operation

Adjustable range

The optical *range* of each OF sensor can be adjusted to meet the specific application.

Highly visible LED function indicator

The LED indicator is visible from the front, back, and top.

Timer with separate LED indicator

All AC/DC sensors with a timer module contain a separate LED indicator which shows the output state, and facilitates the adjustment of the desired time delay.

Low power consumption

The OF sensors distinguish themselves with an extremely small power consumption.

Plug-in terminal strip connector

The connection concept of the OF series combines the advantages of simple installation through a terminal strip with the advantages of a removable connector. The terminal strip connector is supplied with the sensor.



Reliable for the highest demands

Robust construction, glass protected optics

The OF photoelectric sensors are built with a glass-sphere reinforced polyamide housing. A glass window protects the optics against aggressive chemicals and mechanical damage (scratching).

IP 67 sealing

All OF sensors meet the water and dust sealing requirements of IP 67.

EMC-tested

The OF sensors are tested according to IEC 801, EN50081-2 and EN50082-2. This assures trouble free use even in high electromagnetically contaminated environments.

High ambient light rejection

Thanks to pulse modulation and a multilevel disturbance rejection, the OF sensors are extremely insensitive to foreign light sources.

Reverse polarity protection

All of the DC sensor's electrical connections are protected against reverse wiring.

Short-circuit protection

The OF sensor's transistor outputs are electronically protected against short circuit.

Power-up output suppression

During power-up the outputs of the OF sensors are blocked for typically 30 msec.

Designation code

OF X XXX XXX XX

Principle	Supply	Outputs	Connection	Electr. option	Light	Range
E: Through-beam receiver	1: DC 10-30 V 7: AC/DC 24-240 V	KA: No output NA: NPN <i>light- and dark-on</i> PA: PNP <i>light- and dark-on</i> RW: Relay output, 1 CO contact	8: Plug-in terminal strip	00-39: Range adjustable 01: <i>Test input</i> 10: <i>Timer</i> 21: LR output, dynamic, NC 22: LR output, dynamic, NO 23: LR output, static, NC 24: LR output, static, NO 25: <i>Test input</i> and LR output, dynamic, NC 26: <i>Test input</i> and LR output, dynamic, NO 27: <i>Test input</i> and LR output, static, NC 28: <i>Test input</i> and LR output, static, NO 40-79: Range not adjustable 41: <i>Test input</i>	I: Infrared R: Red Q: Red ± 2°	OFS/OFE: 1: 50 m 2: 40 m OFP/OFR: 1: 9 m 2: 18 m OFT/OFH: 1: 1,8 m 2: 0,8 m
H: Diffuse-reflective with background rejection						
P: Retro-reflective with polarizing filters						
R: Retro-reflective						
S: Through-beam emitter						
T: Diffuse-reflective						
Z: Accessory						

Accessories

Retroreflectors: see page 130

Connector cables: see page 128

Mounting:

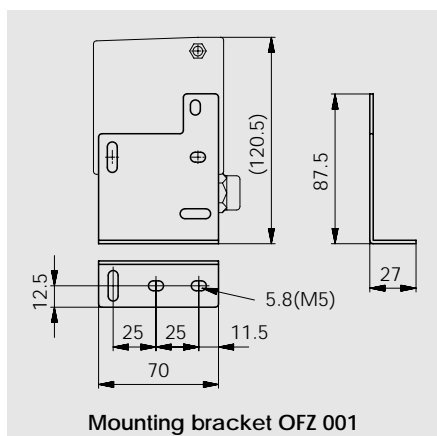

Through-beam sensors, with terminal strip connection



- DC or AC/DC supply voltage
- Short-circuit protected dual transistor outputs (NPN oder PNP) or relay output with 1 change over contact (light-on/dark-on selectable)
- Reverse polarity protection and power-up output suppression
- Light reserve warning indicator
- Test input on DC sensors
- Versions with red light and beam angle $< \pm 2^\circ$ available
- Plug-in terminal strip connector
- Options: - timer with selectable functions (on AC/DC sensors)
- light reserve warning output (on DC sensors)
- EMC tested according to IEC 801 and EN 50081-2/EN 50082-2



Product designation¹⁾

Output

Connection

Range adjustment

Optical data²⁾

Max. range

Emitter

Electrical data²⁾

Supply voltage U_s

Allowable ripple

Current consumption (without load)

Max. load current I_L

Residual voltage

Max. switching frequency

Test input: emitter on
emitter off

Environmental data

Sealing

Temperature T_A
(operating and storage)

Weight

Options¹⁾

Timer functions (selectable)

Timing range

Max. load current of light reserve warning output³⁾

Emitter	Receiver		Emitter	Receiver
OFS 1KA 841 I1	OFE 1NA 800 I1	OFE 1PA 800 I1	OFS 7KA 840 I1	OFE 7RW 800 I1
	NPN (light-/dark-on)	PNP (light-/dark-on)		Relay 1 CO
Plug-in terminal strip				
No	Yes		No	Yes
50 m				
Infrared-LED, 880 nm, pulsed			Infrared-LED, 880 nm, pulsed	
10...30 VDC			24...240 VAC/DC	
+/- 10% of U_s				
< 25 mA	< 15 mA		< 2 VA	
	200 mA			3A
	< 1,6 V			
	1000 Hz			25 Hz
+ U_s or open < 1 V				
IP 67				
-25...+65 °C				
ca. 150 g			ca. 160 g	

	on delay off delay one-shot
	0,1...6 sec.
200 mA	

1) For product designation of sensors with options see designation code on page 105.
2) When not otherwise noted, all technical data at $T_A = 25^\circ\text{C}$ and $U_s = 24\text{ VDC}$ or $U_s = 220\text{ VAC}$, respectively.
3) Light reserve warning output static or dynamic, normally open or normally closed.

24...240 VAC/DC 10...30 VDC

Relay
1 CO contact

NPN / PNP
light-on and
dark-on output



50 m

OFS/OFE

Dimensions (102 mm x 76 mm x 30 mm)

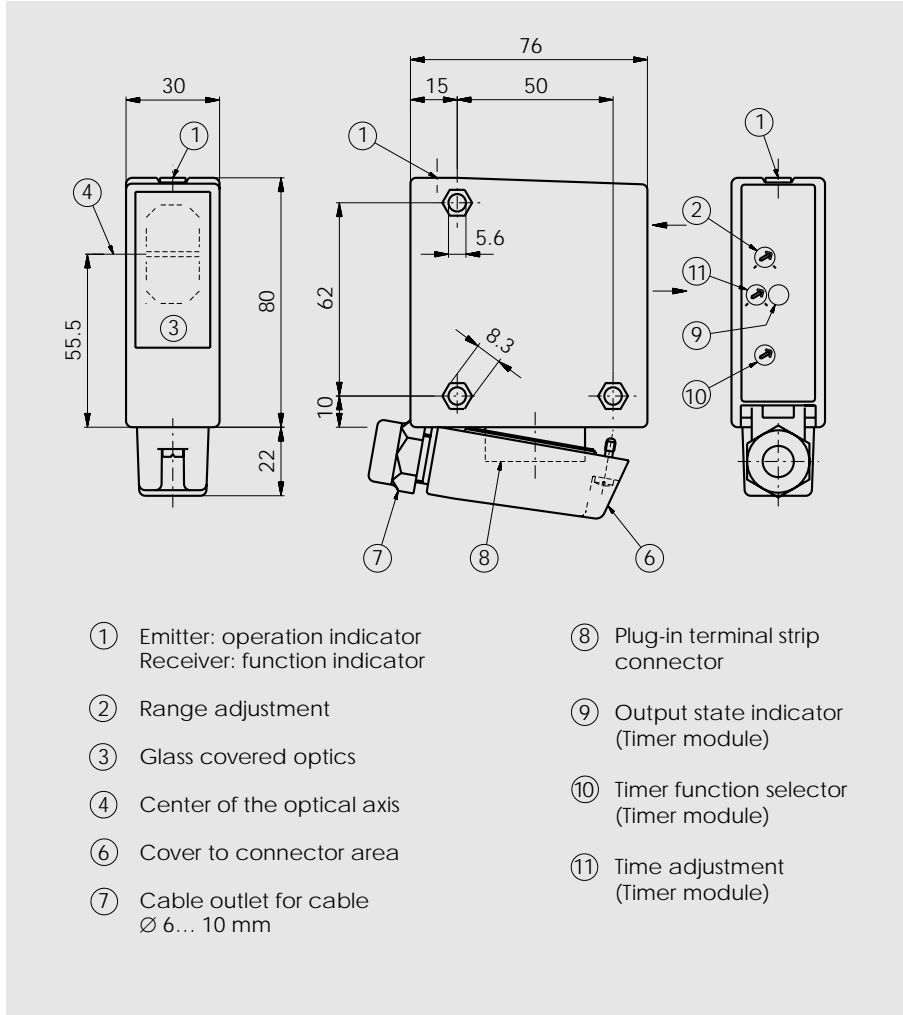

Optical diagrams

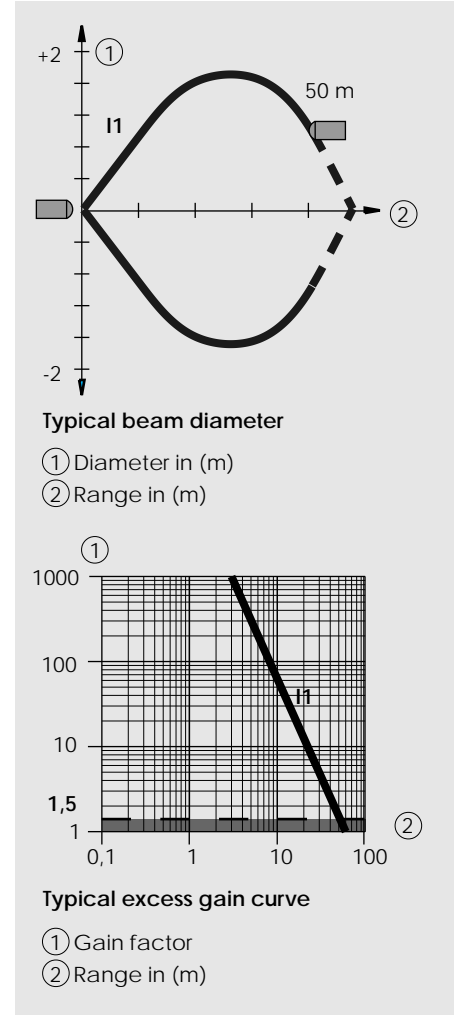

Wiring diagram

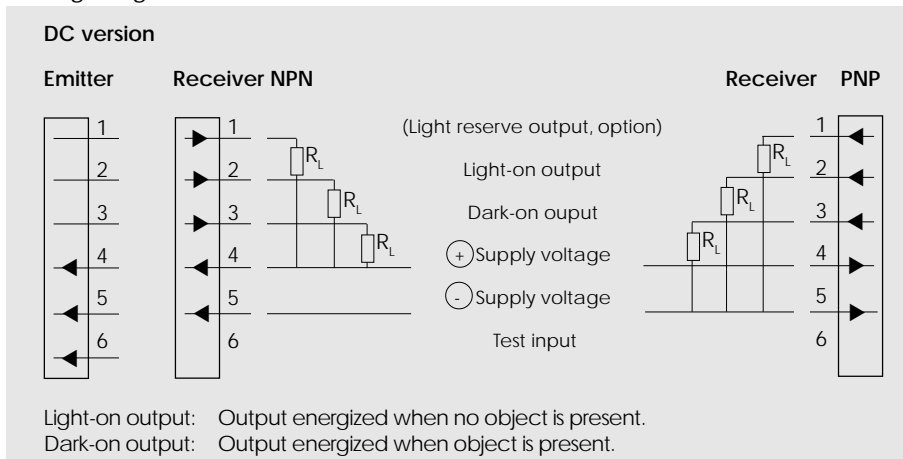

Retro-reflective sensors, with terminal strip connection



- DC or AC/DC supply voltage
- Short-circuit protected dual transistor outputs (NPN oder PNP) or relay output with 1 change over contact (light-on/dark-on selectable)
- Reverse polarity protection and power-up output suppression
- Light reserve warning indicator
- Plug-in terminal strip connector
- Options: - timer with selectable functions (on AC/DC sensors)
- test input (on DC sensors)
- light reserve warning output (on DC sensors)
- EMC tested according to IEC 801 and EN 50081-2/EN 50082-2



Product designation¹⁾

Output
Connection
Range adjustment

Optical data²⁾

Range
Emitter

Electrical data²⁾

Supply voltage U_s
Allowable ripple
Current consumption (without load)
Max. load current I_L
Residual voltage
Max. switching frequency

Environmental data

Sealing
Temperature T_A (operating and storage)
Weight

Options¹⁾

Timer functions (selectable)
Timing range
Test input: emitter on
emitter off
Max. load current of light reserve warning output ³⁾

OFR 1NA 800 I2	OFR 1PA 800 I2	OFR 7RW 800 I2
NPN (light- and dark-on)	PNP (light- and dark-on)	Relay, 1 CO
Plug-in terminal strip		
Yes		
0,3...18 m (retroreflector OZR 001)		
Infrared LED, 890 nm, pulsed		
10...30 VDC		24...240 VAC/DC
+/- 10% of U_s		
< 15 mA		< 2 VA
200 mA		3 A
< 1,6 V		
1000 Hz		25 Hz
IP 67		
-25...+65 °C		
ca. 150 g		ca. 160 g

		on delay off delay one-shot
		0,1...6 sec.
	+ U_s or open	
< 1 V	< $U_s - 8 V$	
200 mA		

1) For product designation of sensors with options see designation code on page 105.
2) When not otherwise noted, all technical data at $T_A = 25\text{ °C}$ and $U_s = 24\text{ VDC}$ or $U_s = 220\text{ VAC}$, respectively.
3) Light reserve warning output static or dynamic, normally open or normally closed.

Retro-reflector ●	Range	Retro-reflector ■	Range	Retro-reflective tape	Range
OZR 001	0.3 – 18 m	OZR 101	0.3 – 11 m	OZR 201*	0.4 – 6 m
OZR 002	0.4 – 16 m	OZR 102	0.3 – 9 m	OZR 202	0.6 – 13 m
OZR 003	0.4 – 8 m	OZR 103	0.4 – 20 m	OZR 203	0.5 – 11 m
		OZR 104	0.4 – 32 m	OZR 204*	0.5 – 11 m
				OZR 205*	0.5 – 15 m

* 30 cm long

ELESTA optosensors



24...240 VAC/DC

10...30 VDC

Relay
1 CO contact

NPN / PNP
light-on and
dark-on output

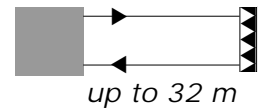

OFR

Dimensions (102 mm x 76 mm x 30 mm)

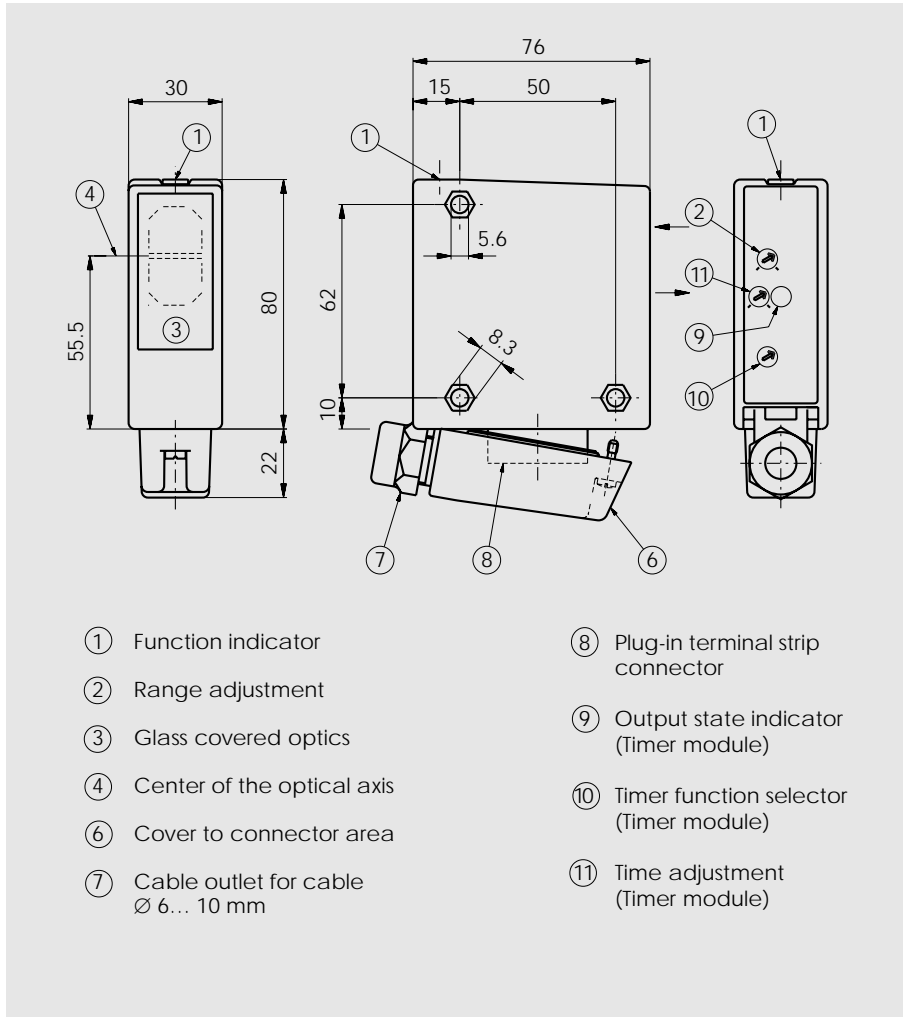

Optical diagrams

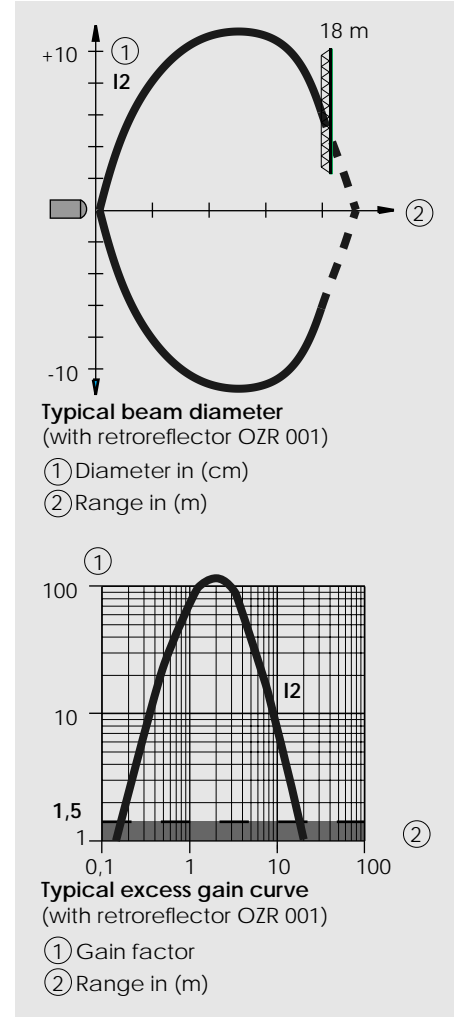

Wiring diagram

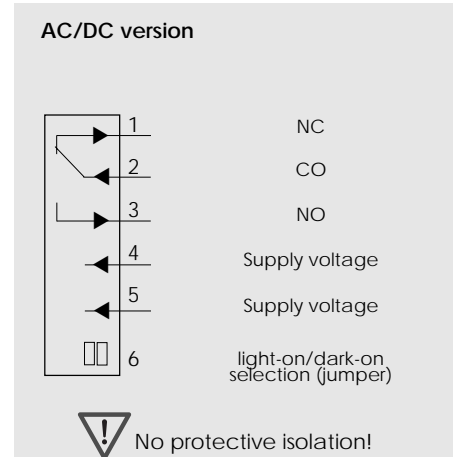
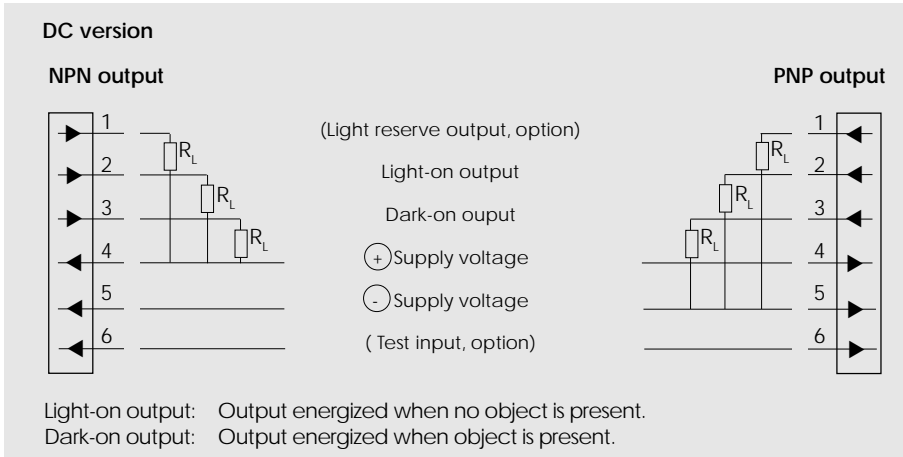

Retro-reflective sensors with polarizing filters and terminal strip connection



- DC or AC/DC supply voltage
- Short-circuit protected dual transistor outputs (NPN oder PNP) or relay output with 1 change over contact (light-on/dark-on selectable)
- Reverse polarity protection and power-up output suppression
- Light reserve warning indicator
- Plug-in terminal strip connector
- Options:
 - timer with selectable functions (on AC/DC sensors)
 - test input (on DC sensors)
 - light reserve warning output (on DC sensors)
- EMC tested according to IEC 801 and EN 50081-2/EN 50082-2



Product designation¹⁾

Output

Connection

Range adjustment

Optical data²⁾

Range

Emitter

Electrical data²⁾

Supply voltage U_s

Allowable ripple

Current consumption (without load)

Max. load current I_L

Residual voltage

Max. switching frequency

Environmental data

Sealing

Temperature T_A
(operating and storage)

Weight

Options¹⁾

Timer functions (selectable)

Timing range

Test input: emitter on

emitter off

Max. load current of light reserve warning output³⁾

	OFP 1NA 800 R1	OFP 1PA 800 R1	OFP 7RW 800 R1
Output	NPN (light- and dark-on)	PNP (light- and dark-on)	Relay, 1 CO
Connection	Plug-in terminal strip		
Range adjustment	Yes		
Range	0,2...9 m (retroreflector OZR 001)		
Emitter	Visible-red LED, 660 nm, pulsed, with polarizing filter		
Supply voltage U_s	10...30 VDC		24...240 VAC/DC
Allowable ripple	+/- 10% of U_s		
Current consumption (without load)	< 15 mA		< 2 VA
Max. load current I_L	200 mA		3 A
Residual voltage	< 1,6 V		
Max. switching frequency	1000 Hz		25 Hz
Sealing	IP 67		
Temperature T_A (operating and storage)	-25...+65 °C		
Weight	ca. 150 g		ca. 160 g

Timer functions (selectable)		on delay off delay one-shot
Timing range		0,1...6 sec.
Test input: emitter on	+ U_s or open	
emitter off	< 1 V	< U_s - 8 V
Max. load current of light reserve warning output ³⁾	200 mA	

1) For product designation of sensors with options see designation code on page 105.
 2) When not otherwise noted, all technical data at $T_A = 25^\circ\text{C}$ and $U_s = 24\text{ VDC}$ or $U_s = 220\text{ VAC}$, respectively.
 3) Light reserve warning output static or dynamic, normally open or normally closed.

Retro-reflector ●	Range	Retro-reflector ■	Range	Retro-reflective tape	Range
OZR 001	0.20 – 9 m	OZR 101	0.15 – 5 m	OZR 201	0 m
OZR 002	0.15 – 8 m	OZR 102	0.15 – 5 m	OZR 202	0 m
OZR 003	0.20 – 4 m	OZR 103	0.10 – 11 m	OZR 203	0.40 – 4.5 m
		OZR 104	0.10 – 18 m	OZR 204*	0.40 – 3.9 m
				OZR 205*	0.40 – 5.4 m

* 30 cm long

ELESTA optosensors



24...240 VAC/DC 10...30 VDC

Relay
1 CO contact

NPN / PNP
light-on and
dark-on output

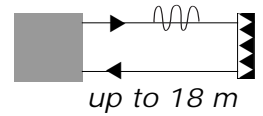

OFF

Dimensions (102 mm x 76 mm x 30 mm)

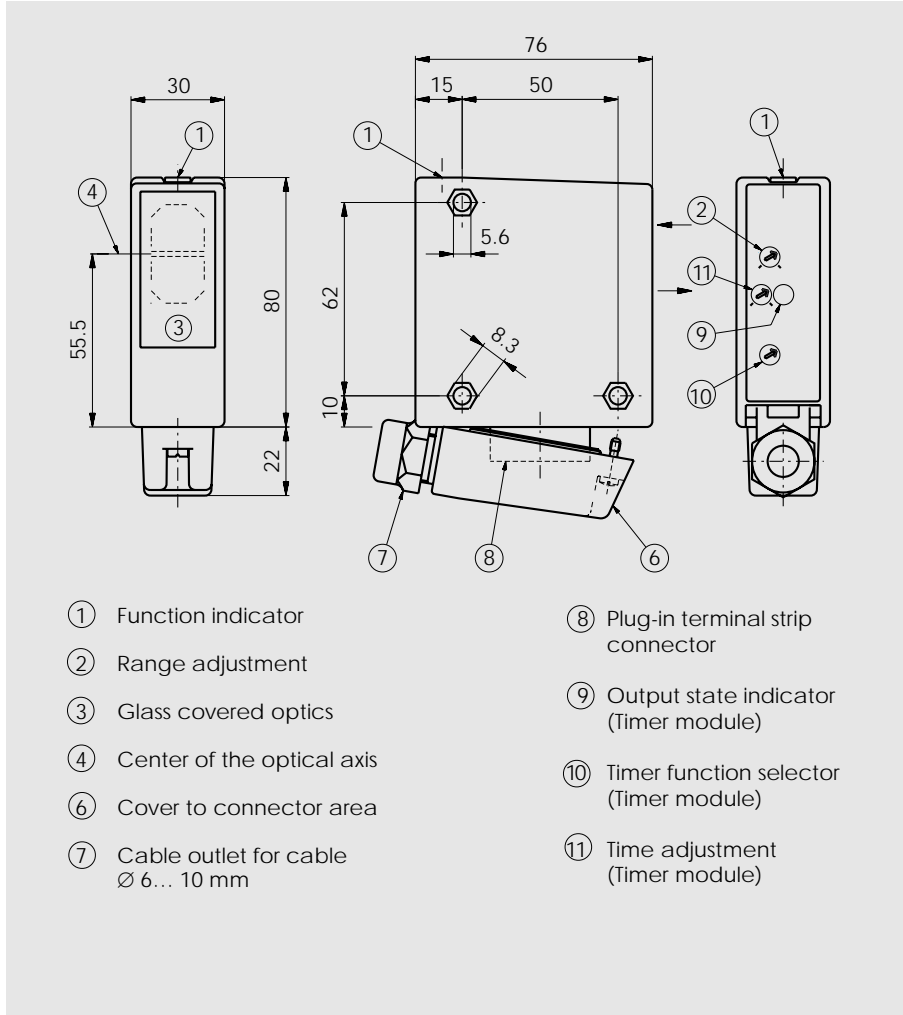

Optical diagrams

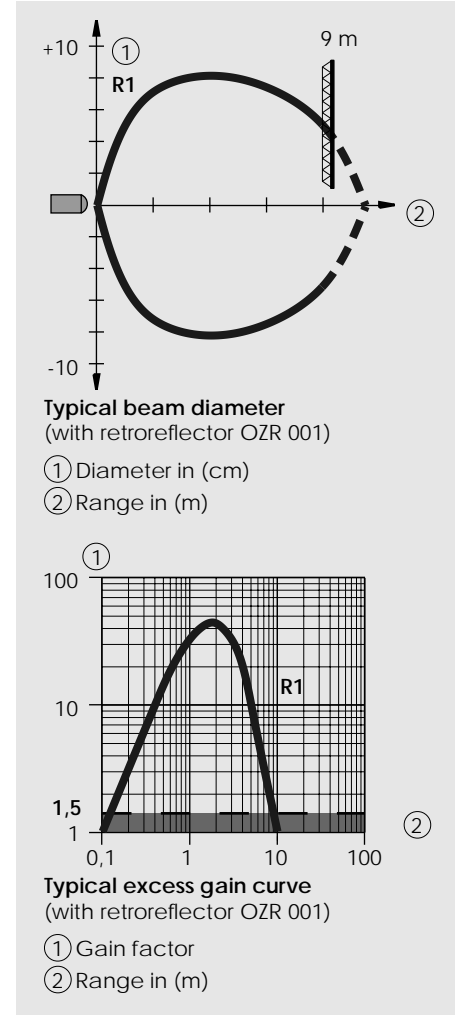

Wiring diagram

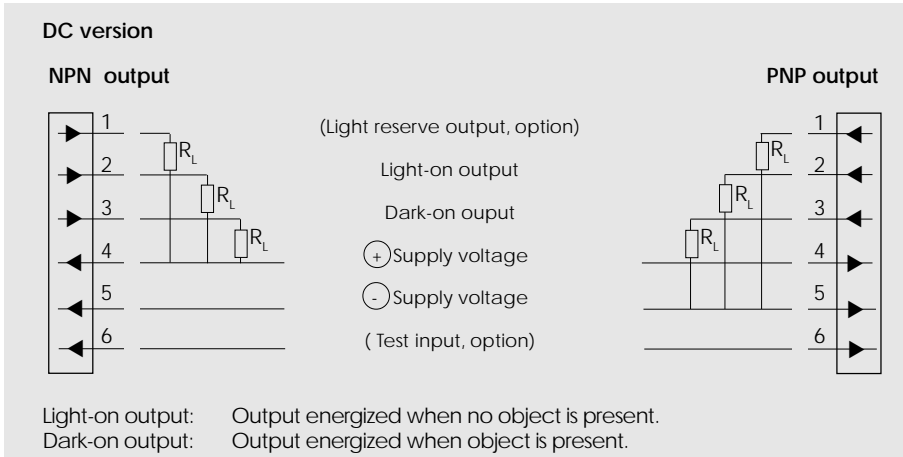

Diffuse-reflective sensors, with terminal strip connection



- DC or AC/DC supply voltage
- Short-circuit protected dual transistor outputs (NPN oder PNP) or relay output with 1 change over contact (light-on/dark-on selectable)
- Reverse polarity protection and power-up output suppression
- Light reserve warning indicator
- Plug-in terminal strip connector
- Options:
 - timer with selectable functions (on AC/DC sensors)
 - test input (on DC sensors)
 - light reserve warning output (on DC sensors)
- EMC tested according to IEC 801 and EN 50081-2/EN 50082-2



Product designation¹⁾

Output
Connection
Range adjustment
Optical data ²⁾
Max. range
Emitter
Electrical data ²⁾
Supply voltage U_s
Allowable ripple
Current consumption (without load)
Max. load current I_L
Residual voltage
Max. switching frequency
Environmental data
Sealing
Temperature T_A (operating and storage)
Weight

OFT 1NA 800 I1	OFT 1PA 800 I1	OFT 7RW 800 I1
NPN (light- and dark-on)	PNP (light- and dark-on)	Relay, 1 CO
Plug-in terminal strip		
Yes		
1,8 m (Kodak card white, 20 x 20 cm)		
Infrared-LED, 880 nm, pulsed		
10...30 VDC		24...240 VAC/DC
+/- 10% of U_s		
< 15 mA		< 2 VA
200 mA		3 A
< 1,6 V		
1000 Hz		25 Hz
IP 67		
-25...+65 °C		
ca. 150 g		ca. 160 g

Options¹⁾

Timer functions (selectable)
Timing range
Test input: emitter on
emitter off
Max. load current of light reserve warning output ³⁾

	on delay off delay one-shot
	0,1...6 sec.
+ U_s or open	
< 1 V	< $U_s - 8V$
200 mA	

1) For product designation of sensors with options see designation code on page 105.
 2) When not otherwise noted, all technical data at $T_A = 25\text{ °C}$ and $U_s = 24\text{ VDC}$ or $U_s = 220\text{ VAC}$, respectively.
 3) Light reserve warning output static or dynamic, normally open or normally closed.

24...240 VAC/DC

10...30 VDC

Relay
1 CO contact

NPN / PNP
light-on and
dark-on output

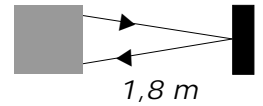

OFT

Dimensions (102 mm x 76 mm x 30 mm)

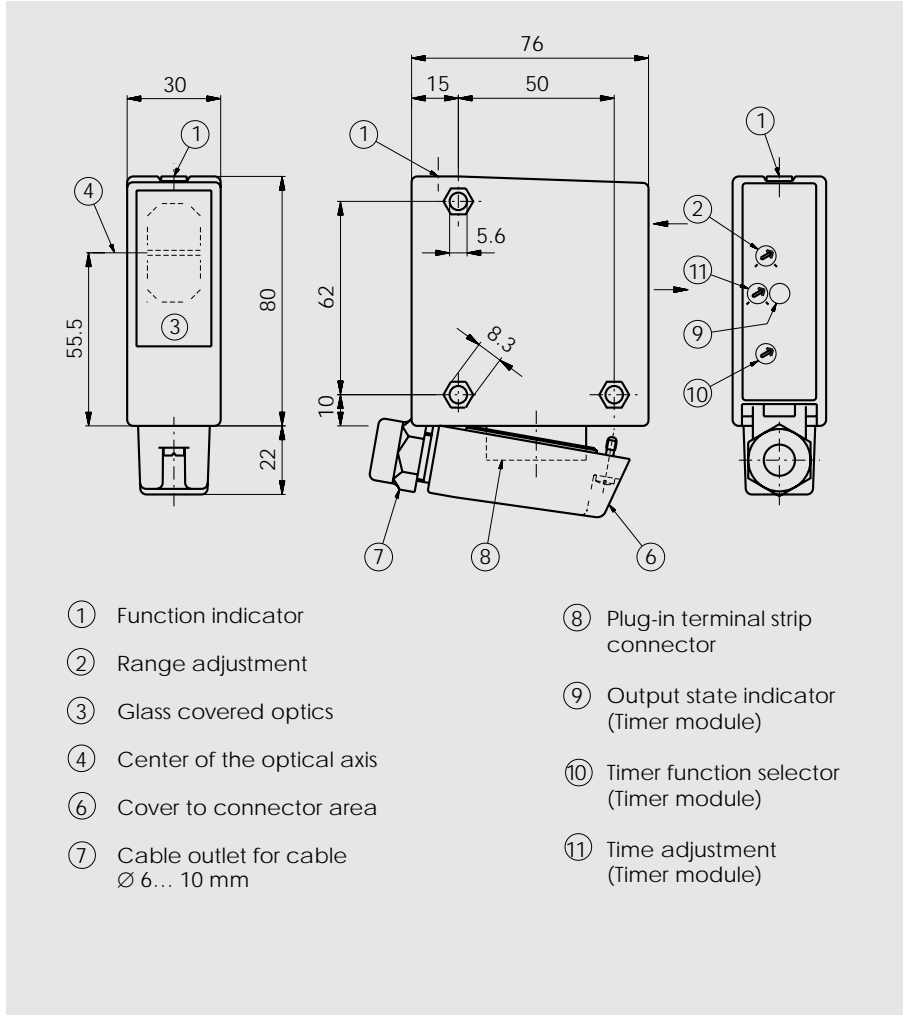

Optical diagrams

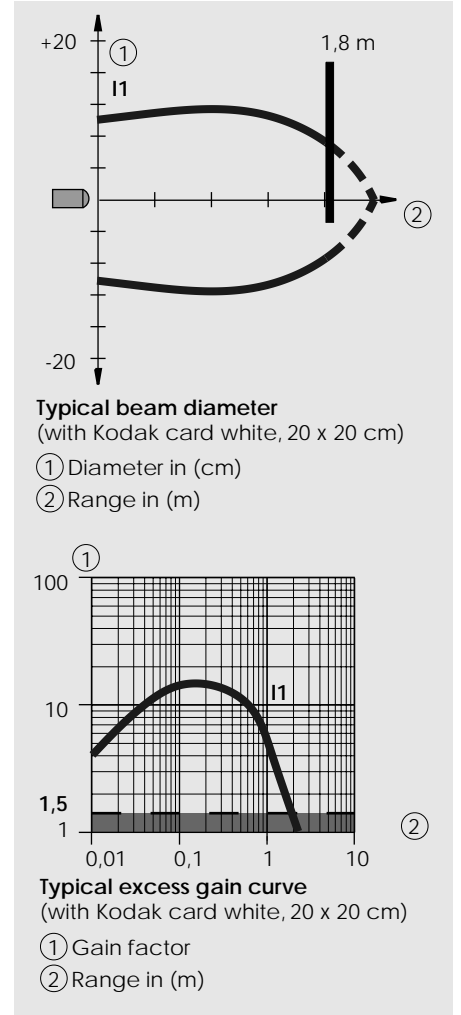

Wiring diagram

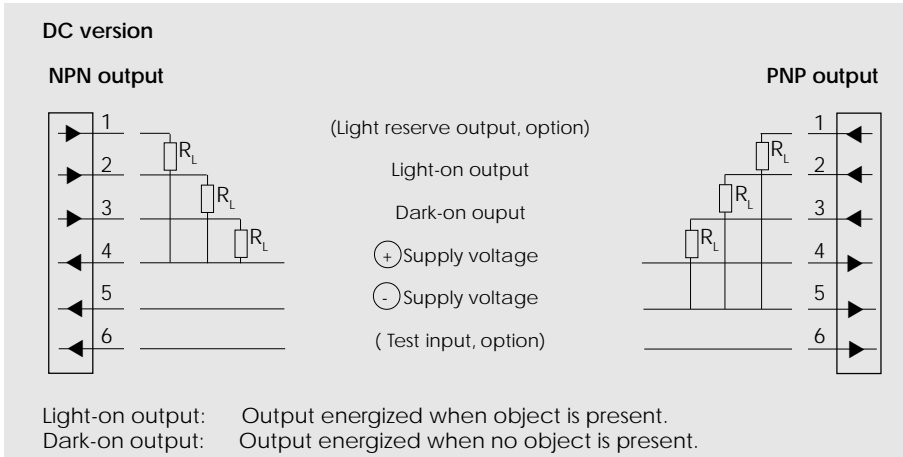

Diffuse-reflective sensors with background rejection and terminal strip connection



- DC or AC/DC supply voltage
- Short-circuit protected dual transistor outputs (NPN oder PNP) or relay output with 1 change over contact (light-on/dark-on selectable)
- Reverse polarity protection and power-up output suppression
- Light reserve warning indicator
- Electronically adjustable background rejection
- Plug-in terminal strip connector
- Options:
 - timer with selectable timing functions (on AC/DC sensors)
 - test input (on DC sensors)
 - light reserve warning output (on DC sensors)
- EMC tested according to IEC 801 and EN 50081-2/EN 50082-2



Product designation¹⁾

Output
Connection
Range adjustment
Optical data ²⁾
Range
Background rejection
Emitter
Electrical data ²⁾
Supply voltage U_s
Allowable ripple
Current consumption (without load)
Max. load current I_L
Residual voltage
Max. switching frequency
Environmental data
Sealing
Temperature T_A (operating and storage)
Weight

OFH 1NA 800 I2	OFH 1PA 800 I2	OFH 7RW 800 I2
NPN (light- and dark-on)	PNP (light- and dark-on)	Relay, 1 CO
Plug-in terminal strip		
Yes		
0,2...0,8 m (Kodak card white, 10 x 10 cm)		
see diagram «Technical explanation» page 102		
Infrared LED, 880 nm, pulsed		
10...30 VDC		24...240 VAC/DC
+/- 10% of U_s		
< 35 mA		< 2 VA
200 mA		3 A
< 1,6 V		
200 Hz		25 Hz
IP 67		
-25...+65 °C		
ca. 180 g		ca. 190 g

Options¹⁾

Timer functions (selectable)
Timing range
Test input: emitter on
emitter off
Max. load current of light reserve warning output ³⁾

		on delay off delay one-shot
		0,1...6 sec.
	+ U_s or open	
< 1 V	< $U_s - 8 V$	
200 mA		

1) For product designation of sensors with options see designation code on page 105.
 2) When not otherwise noted, all technical data at $T_A = 25 °C$ and $U_s = 24 VDC$ or $U_s = 220 VAC$, respectively.
 3) Light reserve warning output static or dynamic, normally open or normally closed.

24...240 VAC/DC

10...30 VDC

Relay
1 CO contact

NPN / PNP
light-on and
dark-on output

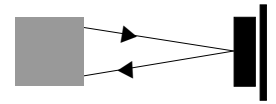

0,2...0,8 m

OFH

Dimensions (102 mm x 76 mm x 30 mm)

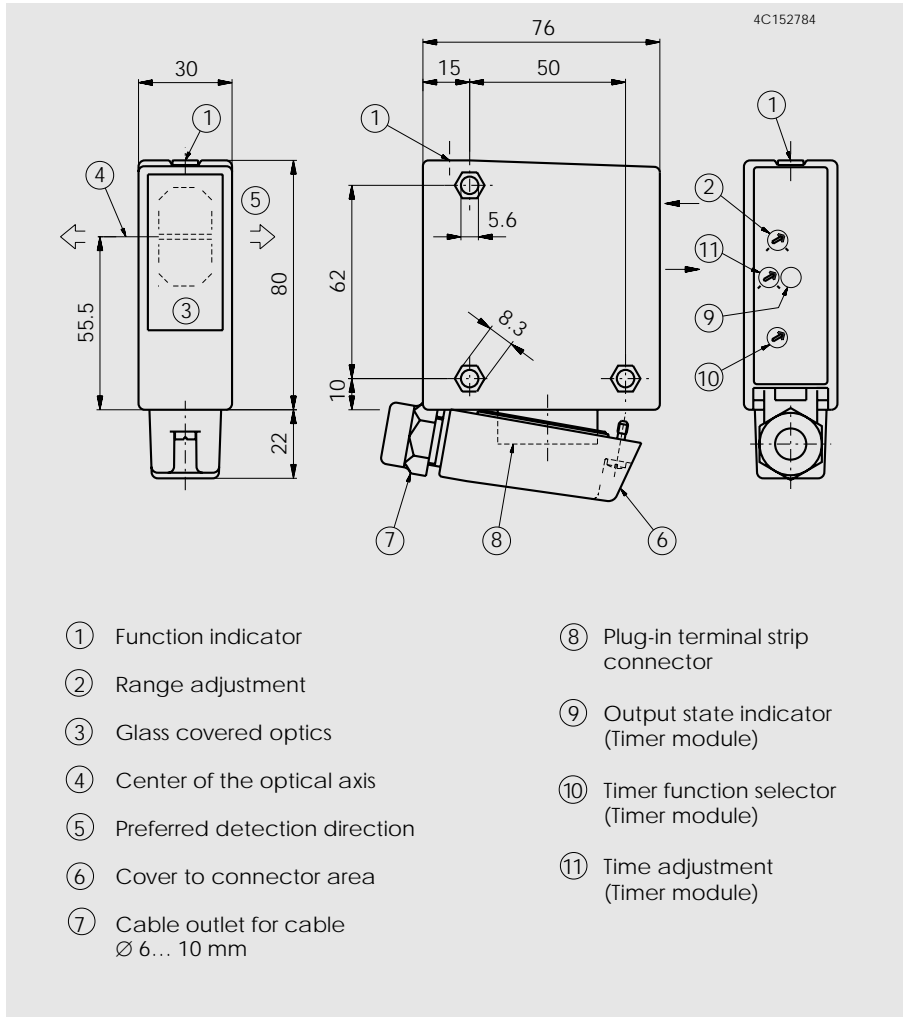

Optical diagrams

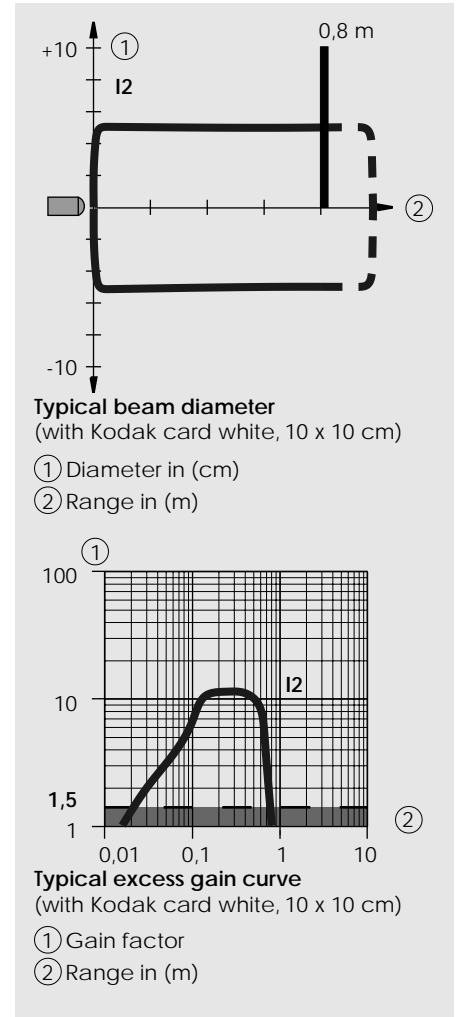

Wiring diagram

